

Operating Instructions

Vertical Contact Toaster 296 & 297 Series

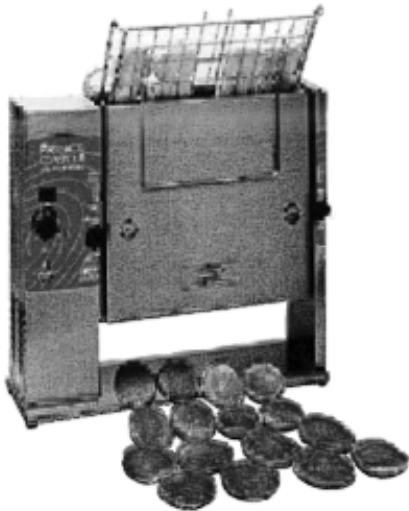

*If you wish to discard electrical and electronic equipment (EEE), please contact your dealer or supplier for further information. This symbol is only valid in the European Union (EU). If you wish to discard this product please contact your local authorities or dealer and ask for the correct method of disposal.

Electrical Specifications

Volts	Hz	Watts	Amps
230	60	1700	7.5
110/120	60	1500	15.5
220	50/60	1700	7.5

Table of Contents

Installation	2
Operation	2
Adjustments	3
Cleaning	4
Troubleshooting	5
Parts List	5 – 8
Wiring Diagram	9

Limited Warranty

This product is warranted to be free from defects in material and/or workmanship for a period of 1 year from date of original installation, not to exceed 18 months from the date of manufacture.

Any component which proves to be faulty in material and/or workmanship will be replaced or repaired (at the option of Prince Castle, Inc.) without cost to the customer for parts and labor. This warranty covers on location service (i.e. trip charges and/or mileage). Travel mileage is limited to 100 miles (200 Kilometers) round trip (one trip warranty) from an authorized service agency or its sub-service agency.

This warranty is subject to the following exceptions/conditions:

- Use of any non-genuine Prince Castle parts voids this warranty.
- All labor to be performed during regular work hours. Overtime premium (the incremental amount) will be charged to the customer.
- Damage caused by carelessness, neglect and/or abuse (e.g., dropping, tampering or altering parts, equipment damaged in shipment, by fire, flood or an act of God) is not covered under this warranty.
- All problems due to operation at voltages other than that specified on equipment nameplates are not covered by this warranty. Conversion to correct voltage is the customer's responsibility.
- This equipment must be serviced by Prince Castle Authorized Service Agency or a Prince Castle Service Technician during the warranty period.
- Normal adjustments as outlined in this manual are not covered under warranty.
- Motors that fail due to the lack of monthly lubrication will not be covered under warranty.

Installation

1. After you have removed the toaster from the carton, inspect the unit for signs of damage. If there is damage to the unit:
 - Notify carrier within 24 hours after delivery.
 - Save carton and packing material for inspection purposes.
 - Contact your Prince Castle dealer or the Prince Castle Customer Sales Department at 1-630-462-8800 if purchased directly.
2. Verify that all parts have been received.
 - Slim-Line Bun Toaster and conveyor assembly.
 - Release Sheet Kit — located in a 14" box.
 - Crumb Tray — taped to the front of the conveyor.
3. Place toaster on flat surface. Remove protective covering.
4. Lift conveyor off conveyor guide rails and set aside. Remove all packing materials (nylon tape, foam block, plastic coating on sheet metal, and black rubber packaging spacers) from conveyor and conveyor guides.

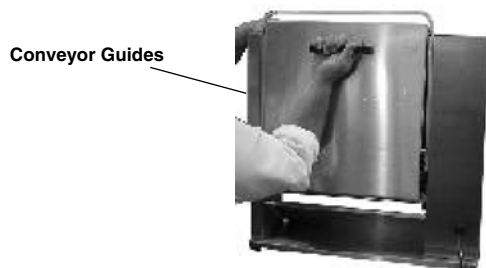

Figure 1

5. Place the Teflon sheet over the top of the platen housing, making sure to have three inches of overhang.

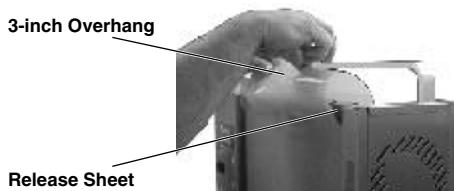

Figure 2

6. Slide the release sheet holding bracket onto the top of the platen housing.

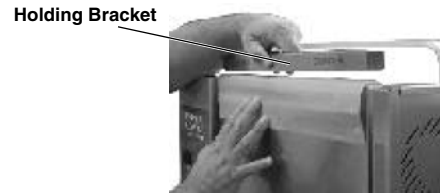

Figure 3

7. Attach conveyor to the toaster by sliding the four pins (conveyor slides) on the conveyor housing into the four conveyor guides. Lower the conveyor housing until it is securely in place.
8. Hook the back end of the crumb tray onto the bar located below the conveyor assembly.
9. Plug unit into a grounded receptacle.

Operation

1. Turn the Power switch to the "On" position. The orange indicator light will illuminate. Allow 30 minutes for platen to reach operating temperature.

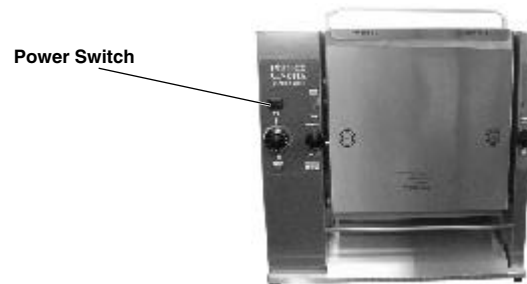

Figure 4

2. Place a sample run of the product being toasted into the top of the conveyor housing. The side to be toasted should face the platen.



Figure 5

3. The toasted product will be dispensed automatically from the bottom of the conveyor assembly.
4. Verify that product meets acceptable standards. If not, see adjustment section.

Adjustments

Conveyor and Motor Gears:

There will be a 1/64" clearance between the conveyor gear and motor gear when properly aligned. Improper alignment will cause the conveyor to periodically bind.

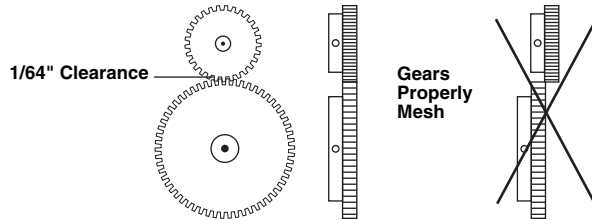

Figure 6

Tools Needed: 3/32" Allen wrench
Wicking grade thread locking fluid

1. Working from the "back side" of the toaster, loosen the 2 setscrews at the bottom of the conveyor guide until they are even with the conveyor stop. Note: the conveyor assembly may need to be removed for easier access.
2. Use the Allen Wrench to tighten the left setscrew (end housing side) until the setscrew just touches the conveyor slide.

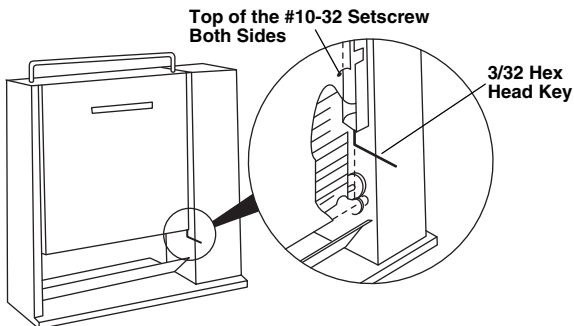

Figure 7

3. Tighten the right setscrew (motor housing side) until the bottom of the conveyor housing is parallel to the top of the base.
4. Carefully tighten each setscrew another 1/2 turn.
5. Remove the conveyor assembly.
6. Apply a drop of wicking grade thread locking fluid to each setscrew.
7. Replace conveyor assembly.

Bun Compression:

The toaster platen can be adjusted to provide the necessary compression needed on various products.

- Turn the two platen adjustment knobs clockwise to compensate for use on thicker bread products. Turn the two platen adjustment knobs counterclockwise for thinner products. The numbers on the front of the end and motor housing will indicate the settings, 1 for thinnest product, 5 for thickest.

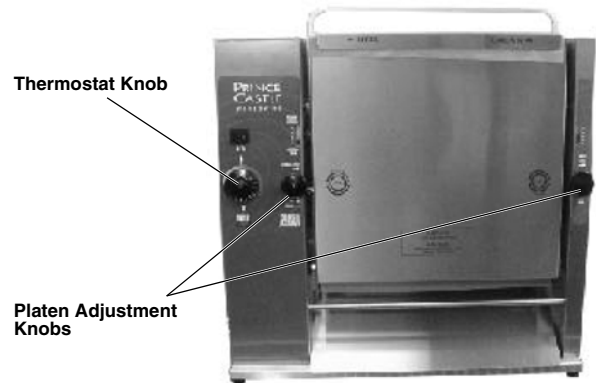

Figure 8

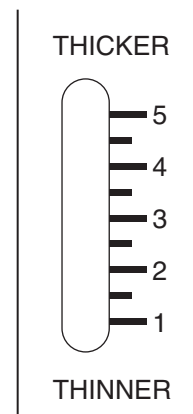

Figure 9

Platen Temperature:

The temperature of the platen can be adjusted to compensate for darker or lighter toasting requirements.

- Turn the thermostat adjustment knob clockwise for darker toasting. Turn the thermostat adjustment knob counterclockwise for lighter toasting.

IMPORTANT: Allow 15 minutes for toaster to stabilize after adjusting the thermostat.

Cleaning

CAUTION: This is not jet-water approved, and should not be cleaned with a water hose or jet spray.

CAUTION: Do not immerse in water.

1. Turn off the Power switch and unplug the toaster.
2. Allow platen to cool for 60 minutes before cleaning.
3. Remove the conveyor assembly.
4. Wipe the conveyor with a damp cloth. For the chain use a soft bristle brush.
5. Remove the release sheet and lay it on a flat surface. Thoroughly clean both sides with a damp cloth making sure all carbon buildup is removed. Allow to air dry.

IMPORTANT: Rotate two sheets daily for longer life. Sheets last 4 – 6 months based on care and volume of product toasted.

6. Use a damp cloth to remove any carbon buildup on the platen surface.

IMPORTANT: Do not use sharp objects, Scotch Brite pads, scouring pads, or abrasive cleaners on the platen or Teflon release sheets as it will cause irreparable damage.

Preventive Maintenance (Motor)

To extend the life of your motor, have a store manager place 2-3 drops of oil on the motor shaft or Oil Hole on a monthly basis.

IMPORTANT: Unplug toaster before performing any preventive maintenance.

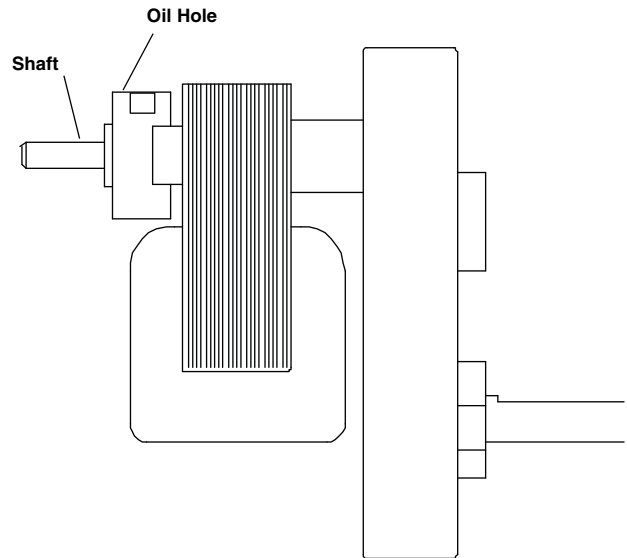
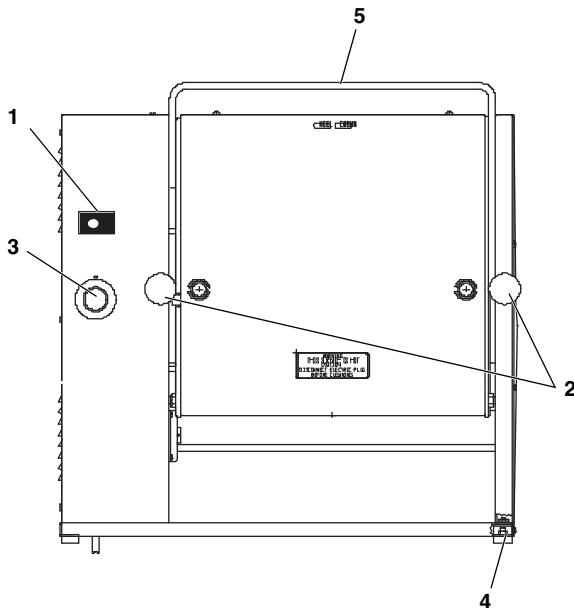

Figure 10

Troubleshooting

PROBLEM	PROBABLE CAUSE	SOLUTION
Unit will not heat up. Power rocker switch light off.	No power to unit. Inoperable power cord. Loose connection on power switch. Inoperable power switch.	Ensure power cord is connected to proper receptacle and the power inlet. Replace power cord. Tighten power switch connections. Replace power switch.
Unit will not heat up. Power rocker switch light on.	Inoperable thermostat. Inoperable platen.	Replace thermostat. Replace platen.
Unit heats up, but the conveyor does not run.	Loose motor switch connection. Inoperable motor. Stripped drive gear. Loose chain sprockets. Gears not meshing. Inoperable motor switch.	Tighten motor switch connection. Replace motor. Replace drive gear. Adjust and tighten sprockets. Adjust conveyor setscrews. (See Conveyor and Motor Gears on page 3). Replace switch.
Unit under- and over-heats (does not respond to thermostat adjustments).	Inoperable thermostat.	Replace thermostat.
Buns under or over done.	Check platen adjustment. (See Bun Compression on page 3.) Check platen temperature. (See Platen Temperature on page 3.)	Adjust platen for proper compression. Adjust thermostat for proper temperature.

Front View



Parts List

Item	Part Number	Description
1	78-184S	Power Lighted Rocker Switch
2	197-185S	Platen Adjustment Knob (Pkg of 2)
3	70-012	Thermostat Knob
4	197-232S	Foot (Pkg of 4)
5	197-124	Conveyor Guide with Handle
*	197-475	Overlay (Motor Housing)
*	197-259	Release Sheet Conversion Kit, 197/297
*	197-402	Release Sheet (Pkg of 2), Conversion Kit 296 Series
*	297-151	Release Sheet (Pkg of 4), 297-T12PHH only
*	297-149	Clamp Bar 297-T12PHH only
*	197-260	Release Sheets (Pkg of 2), 297 Series

* Not shown.

Conveyor Assembly

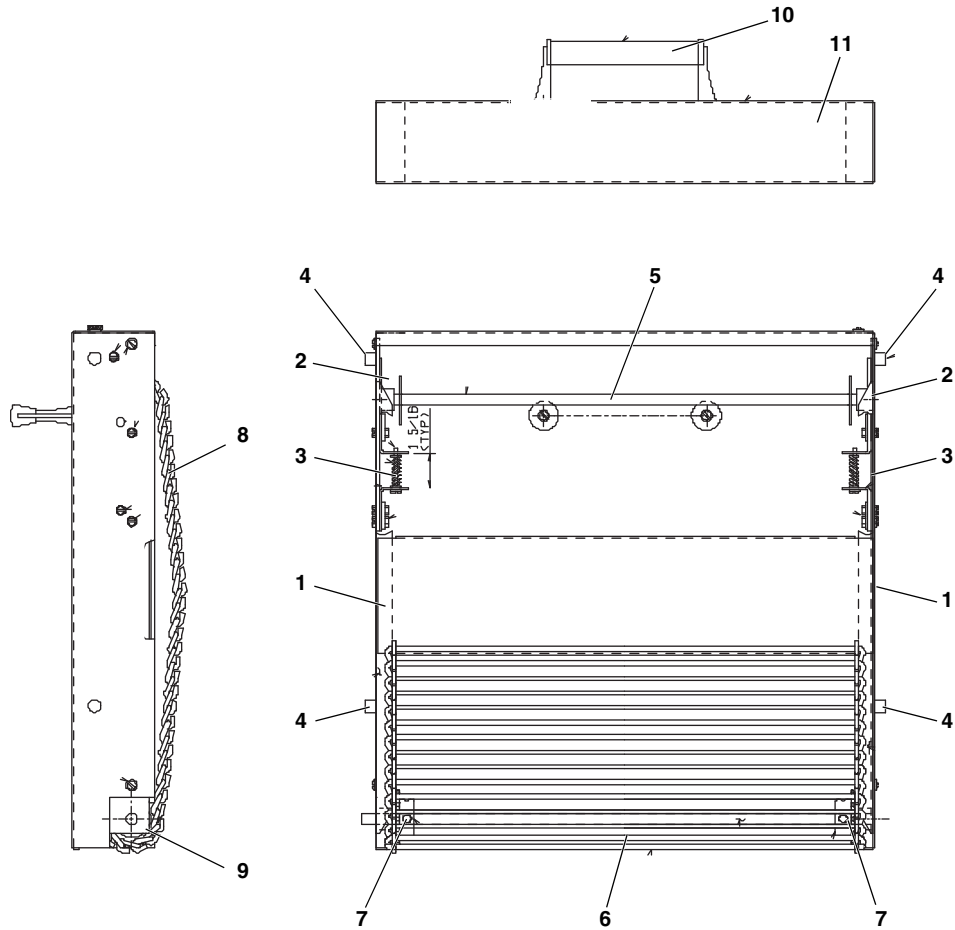

Parts List

Item	Part Number	Description	Item	Part Number	Description
1	197-463S	Left and Right Side Shaft Carrier Assy.	6	197-465	Driven Shaft
2	197-459S	Left and Right Side Shaft Carrier Adjustment Assy.	7	197-302	Sprocket Kit (Pkg of 2)
3	81-015	Compression Spring	8	89-684	Complete Chain Assy.
4	197-467	Conveyor Slide	9	89-590	Single Conveyor Chain Link
5	197-280	Shaft Assy.	10	197-7S	Black Handle with Screw
			11	197-466S	Complete Conveyor Assy. (Passive)

Rear View

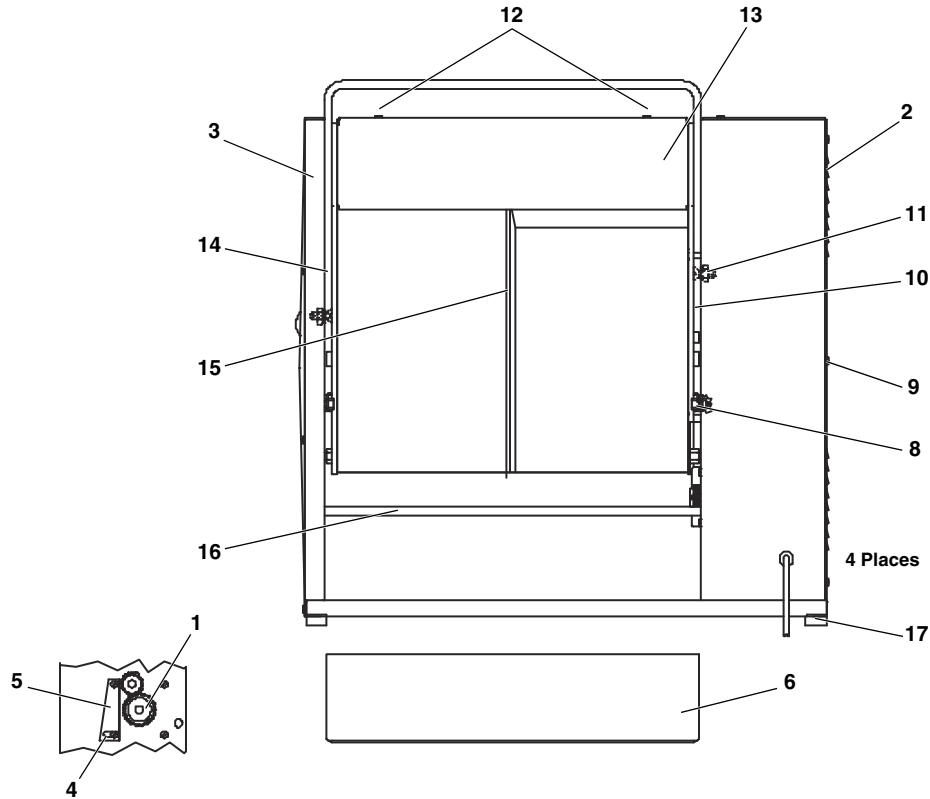

Parts List

Item	Part Number	Description	Item	Part Number	Description
1	197-436S	Gear Kit (20/40 Second)	10	197-96	Left Side Bun Fence
	197-476S	Gear Kit (12 Second)	11	73-008	Self Locking Hex Nut
	197-477S	Gear Kit (14 Second)		73-030	Hex Nut
	197-437S	Gear Kit (30 Second)		79-016	Flat Washer
	196-026S	Gear Kit (55 Second) (196-Jack)		76-033	Slotted Flat Head Screw
	196-025S	Gear Kit (9 Second)	12	76-640	Screw
2	197-114	Motor Cover	13	197-13	Lead Pan Weldment
3	197-473	End Housing	14	197-97	Right Bun Fence
4	76-225	Slotted Pan Head Screw	15	197-431S	Platen (220 Volt) (297)
5	197-131	Guard		197-430S	Platen (110 Volt) (297)
6	197-33	Crumb Tray		196-023S	Platen (110 Volt) (296)
	197-497	Crumb Tray (297-T12PHH only)	16	197-95	Tray Support
8	73-007	Hex Nut	17	72-232S	Line Cord (CE)
	197-16	Conveyor Stop		72-233S	Line Cord (GB)
	76-165	Setscrew		72-280S	Line Cord (120 Volt)
9	76-640	Screw	*		Instruction Card for 297-T12PHH

* Part not shown.

Internal Components

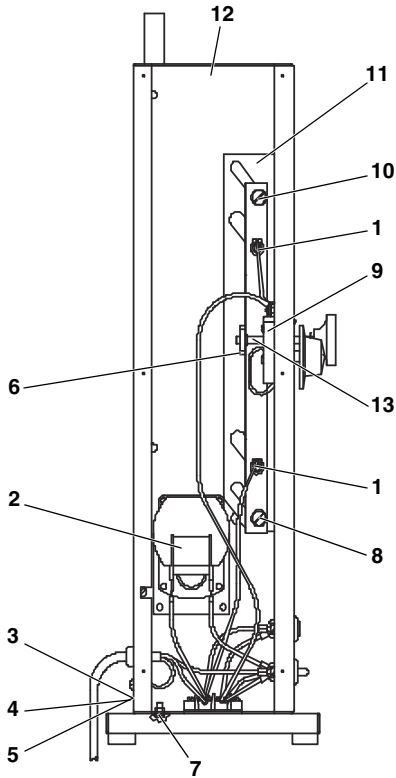

Parts List

Item	Part Number	Description
1	76-300	Slotted Pan Head Screw
2	87-037S	Motor (208-240 Volt)
	87-029S	Motor (120 Volt)
	87-041S	Motor (115V), 9 Sec ONLY
	87-032S	Motor (208 - 240 V), 9 sec ONLY
3	73-031	Hex Nut
4	79-033	Washer
5	76-051	Slotted Binder Head Screw
6	79-055	Flat Washer
7	76-040	Slotted Binder Head Screw
	79-017	Split Lock Washer
	73-030	Hex Nut
8	76-150	Slotted Pan Head Screw
	79-094	Flat Washer
9	79-016	Flat Washer
	76-095	Slotted Binder Head Screw
10	197-90	LH Side Plate Weldment with Adjustment Screw
	197-89	RH Slide Plate Bracket with Adjustment Screw
11	197-428	Baffle (Motor Housing)
	197-429	Baffle (End Housing)
12	196-19	Housing
13	197-140	Thermostat with Knob
	297-010S	Thermostat with Knob and Thermo Compound
*	296-042	Retrofit Kit (9 Second) (50 Hz w/Motor) Includes: (1) 197-436 Gear (24 Teeth) (1) 196-026 Gear (48 Teeth) (2) Allen Key (1) 297-147 Thermostat, 600F (2) 197-257 Teflon Sheets (1) 70-012 T-Stat Knob (1) 87-032 Motor 200/240V
*	296-043	Retrofit Kit (9 Second) (60 Hz w/Motor) Includes: (1) 196-026 Gear w/Pin (48 Teeth) (1) 196-025 Gear (28 Teeth) (2) Allen Key (1) 297-147 Thermostat, 600F (2) 197-257 Teflon Sheets (1) 70-012 T-Stat Knob (1) 87-041 Motor 100/120V

* Part not shown.

Wiring Diagram

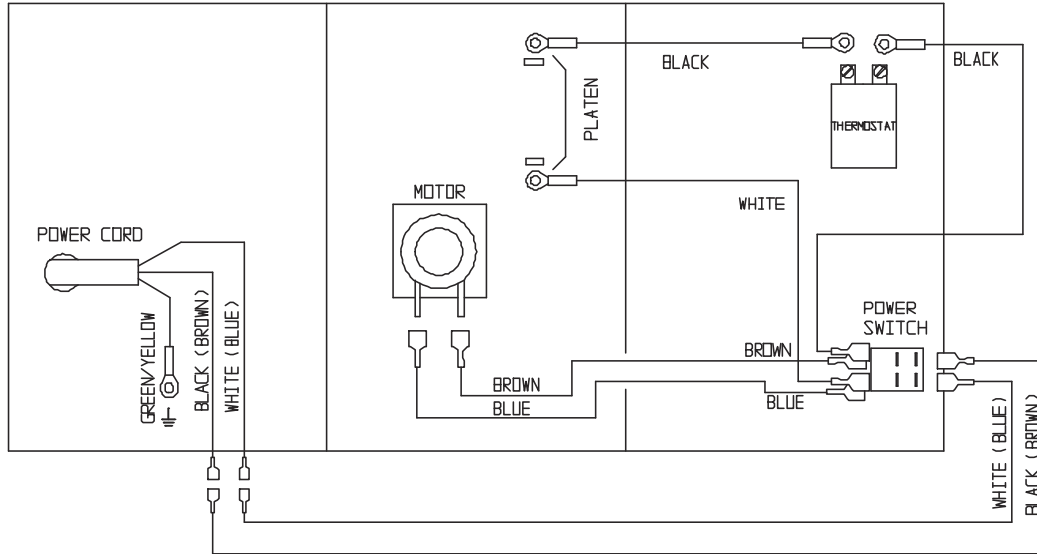

Voltage Connection

High Voltage Connection (220-240 Volts)

Low Voltage Connection (200-208 Volts)

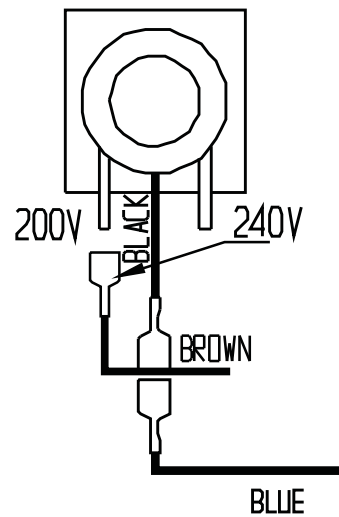
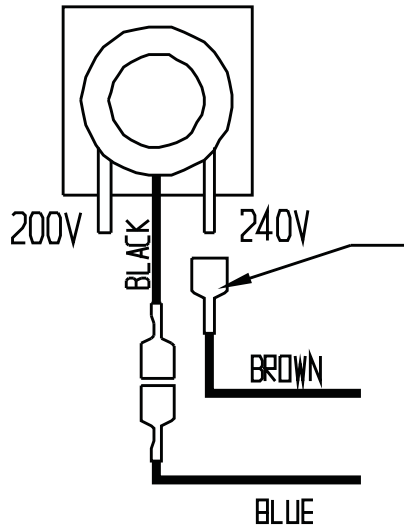

PRINCE CASTLE LLC
WORLDWIDE



A Marmon Group/Berkshire Hathaway Company

355 East Kehoe Blvd. • Carol Stream, IL 60188 USA

Telephone: 630-462-8800 • Fax: 630-462-1460

Toll Free: 1-800-PCASTLE

www.princecastle.com