

OPERATION MANUAL

NCG9&8 Series

Product Identification

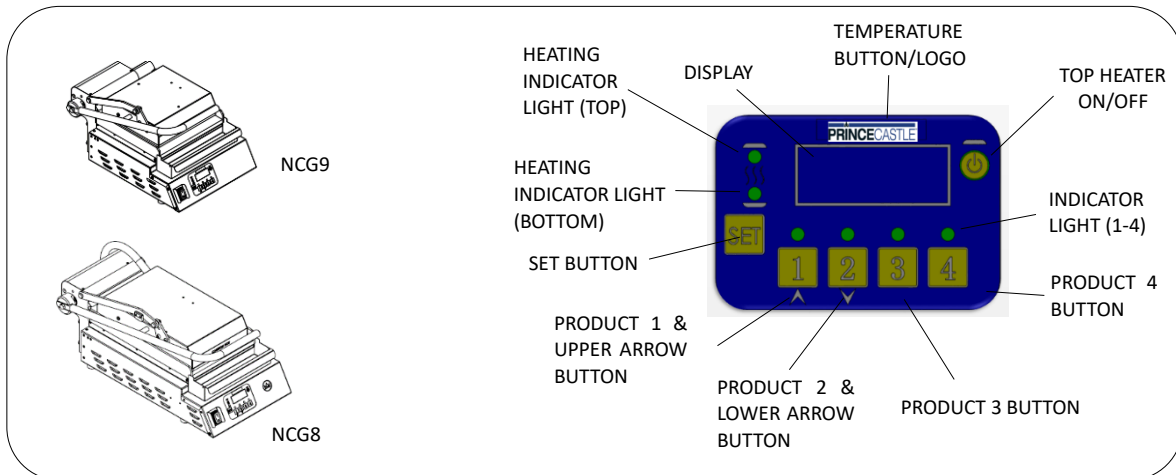

LIMITED WARRANTY

This product is warranted to be free from defects in material and/or workmanship for a period of 1 year from date of original installation, not to exceed 18 months from the date of manufacture.

Any component which proves to be faulty in material and/or workmanship will be replaced or repaired (at the option of Prince Castle, Inc.) without cost to the customer for parts and labor. This warranty covers on-location service (i.e. trip charges and/or mileage). Travel mileage is limited to 100 miles (200 Kilometers) round trip (one trip warranty) from an authorized service agency or its sub-service agency.

This warranty is subject to the following exceptions/conditions:

- Use of any non-genuine Prince Castle parts voids this warranty.
- All labor shall be performed during regular work hours. Overtime premium (the incremental amount) will be charged to the customer.
- Damage caused by carelessness, neglect and/or abuse (e.g. dropping, tampering, or altering parts, equipment damaged in shipment, by fire, flood or an act of God) is not covered under this warranty.
- All problems due to operation at voltages other than that specified on equipment nameplates are not covered by this warranty. Conversion to correct voltage is the customer's responsibility.
- Normal adjustments as outlined in this manual are not covered under warranty.
- This equipment must be serviced by Prince Castle Authorized Service Agency or a Prince Castle Service Technician during the warranty period.
- Wearable items such as (springs, Teflon sheets, bearings) are not Included under warranty.

TABLE OF CONTENTS

Product Identification	1
Safety Information	2
Model specification	2
Installation	3
Initial Start-Up	4
Seasoning the Cooking Surfaces.....	4
Operating Instructions (Electronic Control)...	4
Program Instructions (Electronic Control).....	5
Operating Instructions (Mechanical Control).	5
Daily Cleaning.....	6
Spring adjustment.....	7
Exploding View.....	8
Wiring Diagram	13
Error code table.....	15







Prince Castle LLC (China)

5 floor, Building 8, No. 300 Dingyuan Road, Songjiang District, Shanghai, China, Zip Code 201616

Tel: +86-021-6040-1728 www.princecastle.com

Safety Information

<p> WARNING</p> <p>Indicates information important to the proper operation of the unit. Failure to observe may result in damage to the equipment and/or severe bodily injury or death.</p>	<p> CAUTION</p> <p>This equipment is intended for commercial occasions and operated by trained staff. Operation by untrained personnel or those with reduced physical, sensory or mental capabilities may result in severe injury or death.</p>
<p> CAUTION</p> <p>Indicates information important to the operation of the unit. Failure to observe may result in damage to the equipment.</p>	<p> WARNING</p> <p>Failure to connect unit to rated power supply may cause damage to the unit and voids the warranty.</p>

 **WARNING**

This warning is not for EUROPEAN market: This appliance is not intended for use by persons (including children) with reduced physical, sensory or mental capabilities, or lack of experience and knowledge, unless they have been given supervision or instruction concerning use of the appliance by a person responsible for their safety. Children should be supervised to ensure that they do not play with the appliance.

This warning is only for EUROPEAN market only: This appliance can be used by children aged from 8 years and above and persons with reduced physical, sensory or mental capabilities or lack of experience and knowledge if they have been given supervision or instruction concerning use of the appliance in a safe way and understand the hazards involved. Children shall not play with the appliance. Cleaning and user maintenance shall not be made by children without supervision.

Model Specification

<u>MODEL NO.</u>	<u>WIDTH (mm)</u>	<u>HEIGHT (mm)</u>	<u>DEPTH (mm)</u>	<u>VOLTAGE</u>	<u>POWER</u>
NCG-9-Ex ©	12.6 (320)	22.98 (558)	18.47 (469)	208-240V	2500-3360W
NCG-9-Mx ©	12.6 (320)	22.98 (558)	18.47 (469)	208-240V	2200-3000W
NCG-8-x ©	11.54 (293)	26.64 (677)	23.17 (588)	208-240V 120V	2500-3360W 1908W

NOTE: Height (mm) is when the top plate is open.

© The specific model number please refer to the nameplate on the unit.

Installation

CAUTION

Before using your new equipment, read and understand all the instructions and labels associated with the unit prior to putting it into operation. Make sure all people associated with its use understand the unit's operation and safety before they use the unit.

1. All shipping containers should be checked for freight damage both visible and concealed. This unit has been tested and carefully packaged to insure delivery of your unit in perfect condition. If equipment is received in damaged condition, either apparent or concealed, a claim must be made with the delivering carrier.

NOTE: *Concealed damage or loss – if damage or loss is not apparent until after equipment is unpacked, a request for inspection of concealed damage must be made with carrier within 15 days. Be certain to retain all contents plus external and internal packaging materials for inspection. The carrier will make an inspection and will supply necessary claim forms.*

2. This grill is equipped for the voltage shown on the nameplate. It will operate on alternating current only, however the specified voltage must be applied.

DO NOT CONNECT THE UNIT TO ANY TYPE OF VOLTAGE OTHER THAN THAT ON THE NAMEPLATE. DOING SO WILL DAMAGE THE UNIT AND VOID THE WARRANTY.

DAMAGED POWER CORDS MUST BE REPLACED BY THE MANUFACTURER, ITS SERVICE AGENT OR SIMILARLY QUALIFIED PERSONS IN ORDER TO AVOID A HAZARD.

WARNING

All electrical connections must be in accordance with local electrical codes and any other applicable codes. Plug the unit into an applicable electrical receptacle.

To prevent an electric shock hazard this device must be bonded to equipment in close proximity with an equipotential bonding conductor. This device is equipped with a grounding lug for this purpose and is marked with the following symbol.



Prince Castle reserves the right to change specifications and product design without notice. Such revisions do not entitle the buyer to corresponding changes, improvements, additions or replacements for previously purchased equipment.

Initial Start-Up

1. Place unit on table
2. Before using the unit for the first time, wipe down the exterior and toasting area with a damp cloth.
3. Take to a well ventilated area and heat for approximately 30 minutes.
4. Brush off any debris from the toasting surface.

NOTE: The grill may emit a small amount of smoke as the cooking surfaces reach 512°F (266°C). Do not be alarmed, as the smoke is caused by oils associated with the manufacturing process and will stop when the burn off is complete.

If the cooking platen is made of carbon steel and it may look blue because the cooking surface produced oxide film after heating in production. That is normal, do not affect usage.

Seasoning the Cooking Surfaces

First Time Seasoning

Follow your company/corporate guidelines for seasoning cooking surface, or

1. Bring the grill to 300°F (149°C) and leave it on while doing the next three steps.
2. Brush the cooking surfaces with a release agent. If using an aerosol agent, first apply into a cup and then brush onto cooking surface.
3. Let sit for 20 minutes, and then wipe clean using a warm damp cloth.

Daily Seasoning

The grill should not require much seasoning while in use. In most cases, brushing a light coating of the release agent in the morning and occasionally throughout the day will be enough to prevent any sticking. It is not necessary to brush before grilling each item.

Operating Instructions (Electronic Control)

Cooking Instructions:

1. Start up the unit by placing the power switch into the ON position. The heating indicators, located on the left of window, turn red and the letters "Lo" will display in the window. This indicates the unit is in a warm-up mode. Press one of number product buttons and the LED above it will light. When the preset temperatures of the product button chosen are reached, the heating indicators will turn green and the display window will show time.

NOTE: Initial warm-up time is approximately 20 minutes.

2. Place product on the cooking surface and close the lid.
3. Press the product button for this product and let the display time countdown to "0" at which time the unit will beep. To turn off the alarm, press the product button again.

NOTE: To cancel a program early, just press the product button and hold for 2 seconds.

4. Raise the lid until it stays put at the proper position and remove the food. Using a spatula, scrape residue into the grease tray.
5. Turn the unit off when it is not in use.

NOTE: When not in use it is recommended that the lids be closed to save energy.

View the platen temperature:

To view the unit's actual temperature by pressing the Logo button. The window will display the platen temperature and the corresponding indicator light is on. Press the product button "1" & "2" to view the top and bottom temperature in turn.

Flat Grill Mode:

Press top heater button, located on the right of display window, to turn off the top platen and the top heating indicator light is off simultaneously, activate the bottom platen only. Press the button again, top platen is activated accordingly.

Programming Instructions (Electronic Control)

Program Time and Temperature:

1. Press any number product button and the LED above it will light, then press "SET" button one time and the display will read "____." Enter the four-digit security code sequence: 4, 3, 2, 1.
2. Once the correct sequence has been entered, the preset temperature of top plate will be displayed, set the desired temperature with "1" increase or "2" decrease buttons.
3. Press the "SET" button to save the temperature.
4. Then the preset temperature of bottom plate will be displayed, set the desired temperature with the "1" increase or "2" decrease buttons.
5. Press the "SET" button to save the temperature.
6. The preset time will now displayed, set the desired time with the "1" increase or "2" decrease buttons.
7. Press the "SET" button to save the preset time and exit programming mode.
8. Press other number product button and repeat Step 1 to 7 to continue programming.

Resetting to Factory Defaults:

To revert all settings back to the original factory defaults:

1. Press and hold "SET" button and "1" "2" buttons for 4 seconds.
2. The window will display "FAC." That means to reset to factory defaults.

NOTE: All previously saved settings are lost upon resetting the defaults! Use with caution!

Switch between °F and °C & Temperature

Calibration:

1. Press "SET" button one time and the display will read "____." Enter the four-digit security code sequence: 2, 3, 4, 1.
2. The window will display "dEGC" or "dEGF", set the desired temperature unit with the "1" or "2" buttons.
3. Press the "SET" button to save the change.
4. The window will now display "OF", enter top platen temperature calibration.

NOTE: This process is necessary only when a platen temperature reading on the grill display varies more than a few degrees from the reading of a calibrated pyrometer used to measure the temperature of the same platen. The grill is calibrated before leaving the factory so this process should only be necessary on rare occasions.

5. Set the desired offset value with the "1" increase or "2" decrease buttons in the front of "OF". (*offset = the reading from the pyrometer - display temperature, it is usually a negative*)
6. Press the "SET" button to save the offset value.
7. The window will continue to display "OF" for bottom platen temperature calibration.
8. Set the desired offset value with the "1" increase or "2" decrease buttons before "OF".
9. Press the "SET" button to save the new setting.

Operating Instructions (Mechanical Control)

Cooking Instructions:

1. Turn the unit on by placing the switch in the ON position. The HEAT ON indicator will be lit until it reaches operating temperature. When the unit reaches operating temperature, the heat indicator will turn off.

NOTE: Initial warm-up time is approximately 20 minutes.

2. Place product on the cooking surface and close the lid.
3. After some time raise the lid until it stays put at the proper position and remove the food. Using a spatula, scrape residue into the grease tray.
4. Turn the unit off when it is not in use.

NOTE: When not in use it is recommended that the lids be closed to save energy.

Setting the Temperature:

The thermostat control knob is used to set the temperature to your requirements. The maximum set point is 608°F (320°C), the minimum set point is 122°F (50°C). See Knob Settings.

Typical Knob Setting	
Knob Position	Approx. Temp
1	122°F / 50°C
2	212°F / 100°C
3	302°F / 150°C
4	392°F / 200°C
5	482°F / 250°C
6	572°F / 300°C
7	608°F / 320°C

Daily Cleaning

 **CAUTION**

- DO NOT IMMERSE OR LET THE UNIT STAND IN WATER. DO NOT HOSE DOWN THE UNIT. KEEP THE UNIT AWAY FROM RUNNING WATER.**
- DO NOT SPLASH THE CONTROL HOUSING!**
- DO NOT SPLASH THE CONDUIT CONNECTING THE TOP AND BOTTOM OF THE GRILL!**
- DO NOT USE ICE ON COOKING SURFACE!**

Daily Operating Hours

1. After each cook cycle remove all grease and food residues from the cooking surface with a spatula. The spatula should have rounded corners to prevent the cooking surface from being scratched or marked.
2. Wipe cooking surface with a damp cloth if necessary to minimize grease buildup. If sticking begins to happen on a regular basis, apply a light coat of release agent as described in the "Seasoning the Cooking Surfaces" section of this manual.
3. Empty grease tray at least daily or as necessary during high use periods.

 **CAUTION**

- Never use pumice, griddle stones, or abrasives on platen surface.**
- Never strike the griddle surface with a sharp instrument or spatula edge.**
- Abusing surface voids the warranty.**

After Hours

1. Press and hold "SET" button for 4 seconds to activate the cleaning mode. The window will display "COOL" until both plates cool to 149°C (300°F) and the window displays "CLN".
2. While in the clean mode, remove grease by applying liquid dish detergent(recommend using Ecolab™ Heat Activated Grill & Toaster Cleaner)to the cooking surfaces with a sponge or plastic scrubbing pad
NOTE: cooking surfaces are still hot.
3. Rinse surfaces twice with a clean damp sponge or cloth.
4. Repeat as necessary.
5. Apply a light coat of release agent as described in the "Seasoning the Cooking Surfaces" section of this manual.
6. Use a clean cloth and good nonabrasive cleaner to clean all non- cooking surfaces including the front displays. Wipe all surfaces with a soft cloth.
7. Press top heater button to exit cleaning mode.
8. To remove carbon buildup (a black matter resulting from burnt on food residue, oils, and release agents) from the cooking surfaces, use an approved carbon removal agent (aluminum safe) applied in accordance with the instructions provided with the agent. After this process the cooking surfaces will need to be re-seasoned according to the instructions in the "Seasoning the Cooking Surfaces" section of this manual.

Platen Surface Limited Warranty Exclusions

The grill has been designed to give you many years of cooking reliability and requires minimum maintenance to keep the surface in its original condition. All platen surfaces are warranted for a period of 1 year against manufacturing defects to the original owner from the date of installation. This limited warranty is void if it is determined by Prince Castle or one of its authorized representatives that the platen surface has been misused or abused or subjected to the following situations:

1. Improperly installed.
2. Incorrect voltage applied to unit allowing the surface to overheat and discolor.
3. The misuse of any instrument or tool which scratches or makes indentations in the surface which could cause the surface to peel, flake, or chip off.
4. The use of any chemical or abrasive cleaning solution, griddle brick, stone, screen or other cleaning products which could damage and affect the performance of the platen surface.
5. The neglect of daily routine maintenance to the platen surface.

Spring Adjustment

NOTE: The spring setting which holds the top housing in the up position is set at the factory and should provide many years of use without the need of adjusting.

After an extended period of time the top housing may not maintain its original setting, therefore the spring tension can be adjusted by loosening and tightening the screws on the back of the unit. The detailed steps are as below:

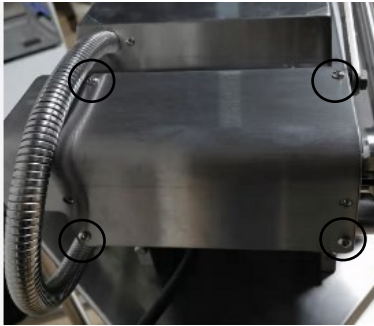

1. Unscrew the screws marked in circles with screwdriver and take the cover off.
3. Put the cover back and attach the screws.

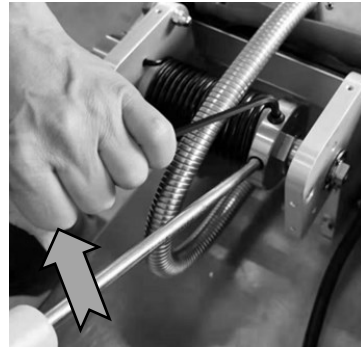

2. Insert the screwdriver into the hole on the collar and hold on, then using a hex wrench (size 3/16), loosen the set screw. To tighten the spring, turn the screwdriver at a proper angle following the arrow. (turn in the opposite direction to loosen the spring), then tighten the set screw.

Note: to get the proper spring pretension force, may need to repeat the operation one or several times.

Exploding View

Model: NCG9 Platen Assembly

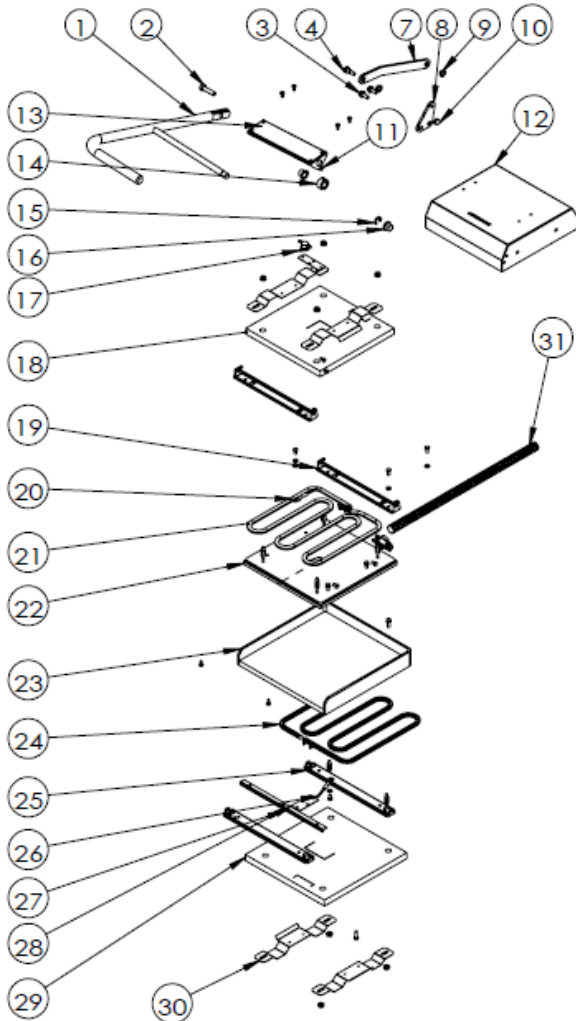

Ite	Part No.	Description	Qty	Application
1	600-309	HANDLE, WELDMENT	1	
2	76-687	BOLT 5/16-18x1.25	1	
3	10-C010	BOLT M6X16	2	
4	600-315	SHOULDER BOLT, LINK	1	
7	600-310	LINK, LIFT	1	
8	600-206	BRKT, ARM, TOP	1	
9	600-210	FLANGE BEARING Ø 8MM	2	
10	CG-066	NUT, HEX CAP, 250-20	1	
11	76-777	SSCUPSKT 0.3125-	1	
12	600-211	WELDMENT, HOUSING, TO	1	
13	600-205	BRACKET, AXIS, TOP	1	
14	600-221	RETAINING RING	1	
15	10-C001	E RING 9 mm	1	
16	600-203	FLANGE BEARING Ø	2	
17	600-C30001	THERMOSTAT	1	
18	600-209	INSULATION, TOP	1	
19	600-217	BRKT, HEATER, TOP	2	
20	600-C305	PROBE, BOT	1	
21	600-200	HEATER, TOP 1400W	1	220V, 1400W
	600-C052	HEATER, TOP 1100W	1	220V, 1100W
22	600-204	PLATEN, TOP, ST, FLAT	1	ST, FLAT
	600-C043	PLATEN, TOP, ST, GROOVED		ST, GROOVED
	600-207	PLATEN, TOP, AL, FLAT		AL, FLAT
	600-C044	PLATEN, TOP, AL, GROOVED		AL, GROOVED
23	600-035	WMT, PLATEN, BOT, ST, F	1	ST, FLAT
	600-C041	WMT, PLATEN, BOT, ST,		ST, GROOVED
	600-043	WMT, PLATEN, BOT, AL, F		AL, FLAT
	600-C042	WMT, PLATEN, BOT, AL,		AL, GROOVED
24	600-037	HEATER, BOT	1	220V, 1400W
25	600-038	BRKT, HEATER, BOT	1	
26	600-C304	PROBE, TOP	1	
27	600-C154	STRIP, GUIDE	1	
28	600-C112	BRKT, HI LIMID PROBE	2	
29	600-041	INSULATION, BOT	1	
30	600-040	BRKT, INSULATION	1	
31	600-C205	Flexible Tube 3/4'	1	

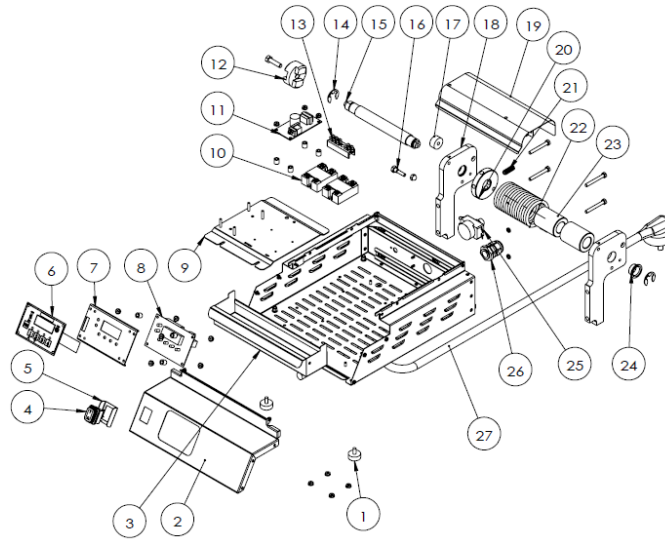

Model: NCG9 Base Assembly

Item	Part No.	Description	Qty	Application
1	197-232	FOOT, MOUNTING	4	
2	600-413	PANEL, FRONT	1	Mechanical Version
	600-C156	PANEL, FRONT		
3	600-405	GREASE TRAY	1	
4	78-233	SWITCH,ROCKER,DPST,IP65,16A	1	
5	542-164	GUARD,SWITCH	1	
6	600-C303	OVERLAY, DISPLAY	1	
7	600-407	PLATE, OVERLAY	1	
8	600-C302	MAIN PCB	1	
9	600-C194	PLATE, RALAY	1	
10	65-058	RELAY	2	
11	PM-096	TRANSFORMER	1	
12	600-312	COUPLER, HANDLE	1	
13	77-082	TERMINAL BLOCK, 5 POS	1	
14	10-C003	E RING 15 mm	2	
15	600-308	SHAFT, SPRING	1	
16	600-314	SHOULDER BOLT, MOUNT	1	
17	600-311	STOP, LIFT	1	
18	600-303	BLOCK, MOUNT, TORSION	2	
19	600-302	COVER-SPRING	1	
20	600-305	COLLAR, TORSION	1	
22	600-316	TORSION SPRING	1	FOR ALUMIUM PLATEN
	600-306	TORSION SPRING		FOR STEEL PLATEN
23	600-C402	SPACER, SPRING	2	FOR ALUMIUM PLATEN
	600-307	SPACER, SPRING		FOR STEEL PLATEN
24	600-304	FLANGE BEARING Ø 20MM	2	
25	301-117	HI-LIMIT THERMOSTAT	1	
26	066-045	RELIEF,STRAIN,LIQUID TIGHT	1	
27	PM-123A	POWER CORD W/ PLUG	1	CH2-16P
	72-381	POWER CORD W/ PLUG	1	IEC309
	CG-567A/C	POWER CORD & PLUG	1	NEMA 6-20P
28	600-C300	THERMOSTAT,EGO	1	Not Shown, Mechanical Version
29	071-134-1	INDICATOR LIGHT	1	Not Shown, Mechanical Version

Model: NCG8 Platen Assembly

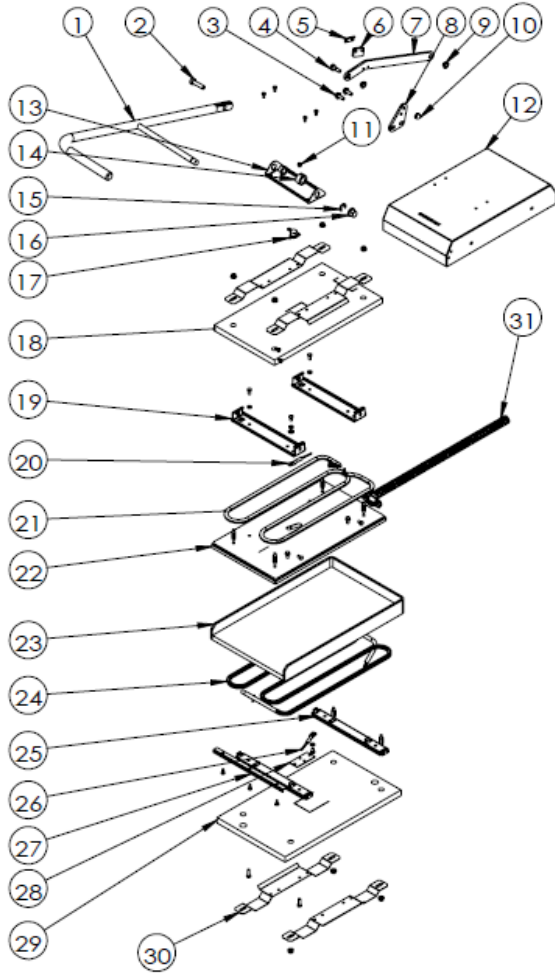

Item	Part No.	Description	Qty	Application
1	600-C186	HANDLE, WELDMENT	1	
2	76-687	BOLT 5/16-18x1.25	1	
3	10-C010	BOLT M6X16	2	
4	600-315	SHOULDER BOLT, LINK	1	
5	600-C181	MOUNT, RUBBER	1	
6	600-C401	RUBBER,BUFFER	1	
7	600-C177	LINK, LIFT	1	
8	600-C178	BRKT, ARM, TOP	1	
9	600-210	FLANGE BEARING Ø 8MM	2	
10	CG-066	NUT,HEX CAP,250-20	1	
11	76-777	SSCUSPKT 0.3125-18x0.3125	1	
12	600-C219	WELDMET,HOUSING,TOP	1	
13	600-C179	BRACKET, AXIS, TOP	1	
14	600-221	RETAINING RING	1	
15	10-C001	E RING 9 mm	1	
16	600-203	FLANGE BEARING Ø 12MM	2	
17	600-C30001	THERMOSTAT	1	
18	600-C207	INSULATION, TOP	1	
19	600-C203	BRKT, HEATER, TOP	2	
20	600-C305	PROBE. BOT	1	
21	600-C204-1	HEATER, TOP	1	220V, 1300W
	600-C204-3	HEATER, TOP		120V, 800W
22	600-C202	PLATEN, TOP, ST, FLAT	1	ST, FLAT
	600-C214	PLATEN, TOP, ST, GROOVED		ST, GROOVED
	600-C216	PLATEN, TOP, AL, FLAT		AL, FLAT
	600-C215	PLATEN, TOP, AL, GROOVED		AL, GROOVED
23	600-C196	WMT, PLATEN, BOT, ST, F	1	ST, FLAT
	600-C217	WMT, PLATEN, BOT, ST, GROOVED		ST, GROOVED
	600-C211	WMT, PLATEN, BOT, AL, F		AL, FLAT
	600-C218	WMT, PLATEN, BOT, AL, GROOVED		AL, GROOVED
24	600-C198-1	HEATER, BOT	1	220V, 1500W
	600-C198-3	HEATER, BOT		120V, 1100W
25	600-C197	BRKT, HEATER, BOT	2	
26	600-C304	PROBE. TOP	1	
27	600-C199	STRIP, GREASE	1	
28	600-C112	BRKT, HI LIMID PROBE	1	
29	600-C206	INSULATION, BOT	1	
30	600-C171	BRKT, INSULATION	4	
31	600-C205	Flexible Tube 3/4'	1	

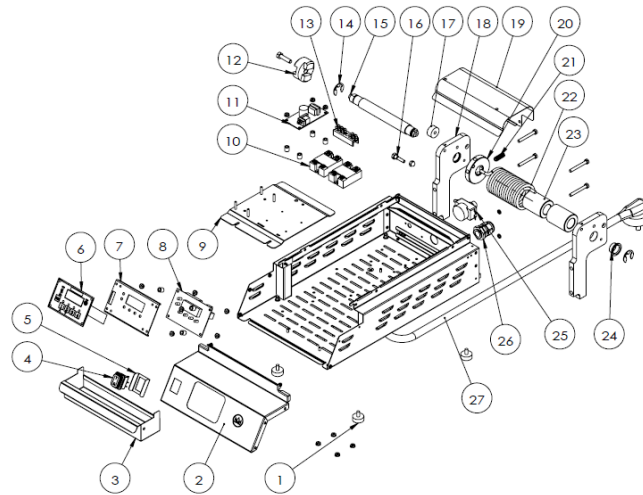

Model: NCG8 Base Assembly

Item	Part No.	Description	Qty	Application
1	197-232	FOOT, MOUNTING	4	
2	600-C191	WELDMENT,PANEL, FACE	1	
3	600-C195	WMT, GREASE TRAY	1	
4	78-233	SWITCH,ROCKER,DPST,IP65,16A	1	
5	542-164	GUARD,SWITCH	1	
6	600-C303	OVERLAY, DISPLAY	1	
7	600-407	BACKER, DISPLAY	1	
8	600-C302	MAIN PCB	1	
9	600-C194	PLATE, RALAY	1	
10	65-058	RELAY	2	
11	PM-096	TRANSFORMER	1	220V
	PM-042	TRANSFORMER		120V
12	600-312	COUPLER, HANDLE	1	
13	77-082	TERMINAL BLOCK, 5 POS	1	
14	10-C003	E RING 15 mm	2	
15	600-308	SHAFT, SPRING	1	
16	600-314	SHOULDER BOLT, MOUNT	1	
17	600-311	STOP, LIFT	1	
18	600-303	BLOCK, MOUNT, TORSION	2	
19	600-C200	COVER-SPRING	1	
20	600-305	COLLAR, TORSION	1	
21	10-C004	SSCUPSKT 0.375-16x1-HX-S	1	
22	600-306	TORSION SPRING	1	
23	600-307	SPACER, SPRING	2	
24	600-304	FLANGE BEARING Ø 20MM	2	
25	301-117	ELECTRIC THERMOSTAT, DBL POLE,	1	
26	066-045	RELIEF,STRAIN,LIQUID TIGHT	1	
27	PM-123A	POWER CORD W/ PLUG	1	CH2-16P
	72-381	POWER CORD W/ PLUG	1	IEC309
	CG-567A/C	POWER CORD & PLUG	1	NEMA 6-20P
	72-470	POWER CORD & PLUG	1	NEMA 5-30P
28	600-C300	THERMOSTAT,EGO	1	Not Shown, Mechanical Version
29	071-134-1	INDICATOR LIGHT	1	Not Shown, Mechanical Version

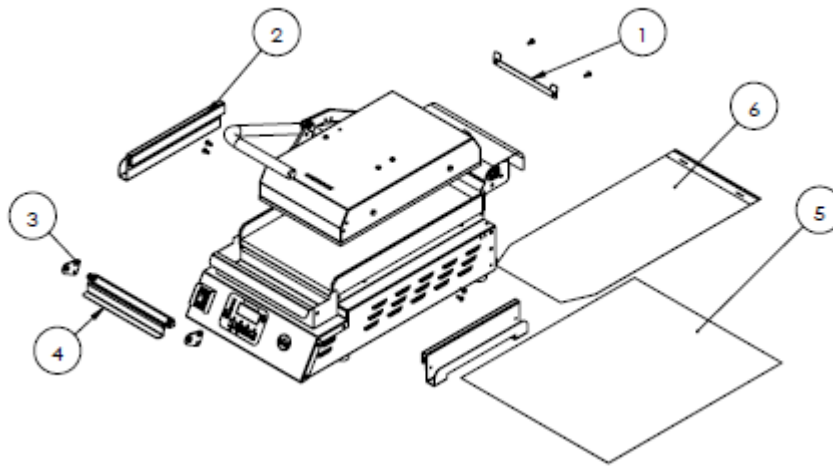

Model: NCG9&8 Teflon sheet kit (optional):

Item	Part No.	Description	Qty	Application
1	600-C103	HOOK	1	
2	600-C104	HOLDER	2	
3	600-C107	BRACKET	2	
4	600-C114	TOP CLAMP	1	NCG9
	600-C101	TOP CLAMP	1	NCG8
5	600-C404	TEFLON SHEET, BLACK 390*300	1	NCG9
	600-C406	TEFLON SHEET, BLACK 430*365	1	NCG8
6	600-C403	TEFLON SHEET, BROWN 350*238	1	NCG9
	600-C405	TEFLON SHEET, BROWN 470*211	1	NCG8

Note: for safety, please use only this Teflon sheet paper recommended by manufacture.

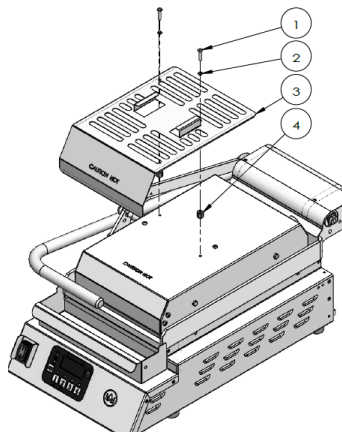

Model: NCG9&8 heat shield kit (optional):

Item	Part No.	Description	Qty	Application
1	PM-125	SCREW,P.NPH,SS,8-32 X3/8	2	
2	79-031	WSHR,SPLIT-LOCK S.S.	2	
3	600-C048	HEAT SHIELD,NCG9	1	NCG9
	600-C049	HEAT SHIELD,NCG8	1	NCG8
4	86-561	HEX NUT STANDOFF	2	

Wiring Diagram

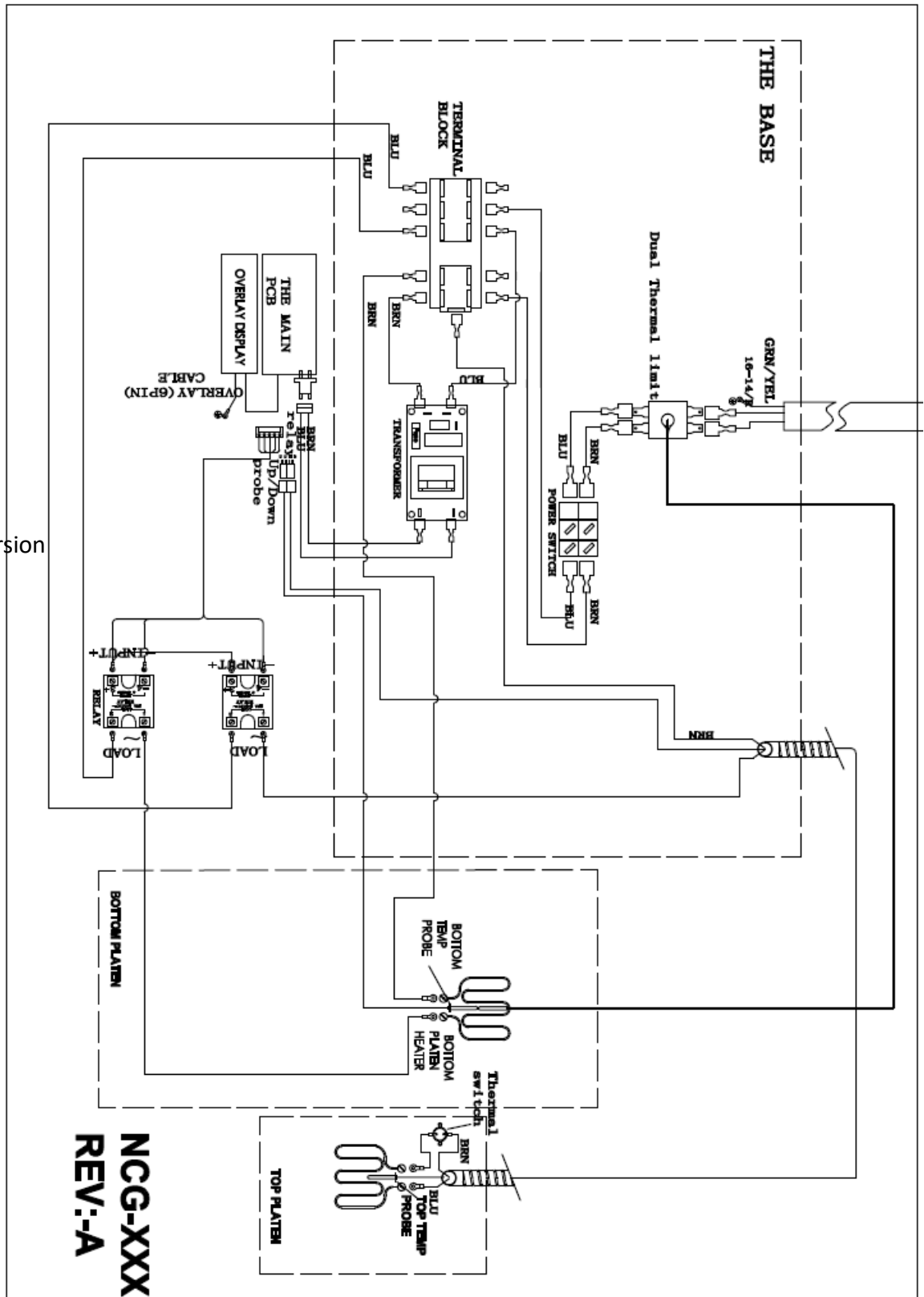

Electronical Control Version

**NCG-XXX
 REV:-A**

Error Code Table

Error Code	Criteria	Action
E11	The set temperature of the top heating plate is not reached within 20 minutes.	Check top heater and top Heater relay
E21	The temperature of the top heating plate exceeds 315 degrees	Check top heater and top Heater relay
E12	The set temperature of the bottom heating plate is not reached within 20 minutes.	Check bottom heater and top Heater relay
E22	The temperature of the bottom heating plate exceeds 315 degrees	Check bottom heater and top Heater relay
E31	Top RTD fails causing an open circuit (Resistance >= 2810 ohms)	Replace top RTD
E32	Bottom RTD fails causing an open circuit (Resistance >= 2810 ohms)	Replace bottom RTD
E41	Incorrect RTD installed for the top (Resistance <= 922 ohms)	Replace top RTD
E42	Incorrect RTD installed for the bottom (Resistance <= 922 ohms)	Replace bottom RTD
E5	Write operation failed or memory corrupted (CRC)	Replace PCB Board
E6	A button is broken and is always pressed for more than 30 seconds	Check PCB Board and Overlay