

Operation Manual

Contact Grill
CG14G-2TP

Product Identification



LIMITED WARRANTY

This product is warranted to be free from defects in material and/or workmanship for a period of 1 year from date of original installation, not to exceed 18 months from the date of manufacture.

Any component which proves to be faulty in material and/or workmanship will be replaced or repaired (at the option of Prince Castle, Inc.) without cost to the customer for parts and labor. This warranty covers on-location service (i.e. trip charges and/or mileage). Travel mileage is limited to 100 miles (200 Kilometers) round trip (one trip warranty) from an authorized service agency or its sub-service agency.

This warranty is subject to the following exceptions/conditions:

- Use of any non-genuine Prince Castle parts voids this warranty.
- All labor to be performed during regular work hours. Overtime premium (the incremental amount) will be charged to the customer.
- Damage caused by carelessness, neglect and/or abuse (e.g., dropping, tampering, or altering parts, equipment damaged in shipment, by fire, flood or an act of God) is not covered under this warranty.
- All problems due to operation at voltages other than that specified on equipment nameplates are not covered by this warranty. Conversion to correct voltage is the customer's responsibility.
- Normal adjustments as outlined in this manual are not covered under warranty.
- This equipment must be serviced by Prince Castle Authorized Service Agency or a Prince Castle Service Technician during the warranty period.
- Wearable items such as (springs, Teflon sheets, bearings) are not included under warranty.

TABLE OF CONTENTS

Product Identification	1
Safety Information	2
Electrical Specifications	2
Model Number	2
Installation	2
Initial Start-Up	3
Seasoning the Cooking Surfaces (Non Chrome Surfaces)	3
Operating Instructions	3
Programming Instructions	4
Monthly Inspection	5
Cleaning	5
Platen Temperature Calibration	6
Exploded View	7
Split Top Wiring Diagrams	8



PRINCE CASTLE LLC 
WORLDWIDE



A Marmon Group/Berkshire Hathaway Company

355 East Kehoe Blvd. • Carol Stream, IL 60188 USA
Telephone: 630-462-8800 • Toll Free: 1-800-PCASTLE
Fax: 630-462-1460 • www.princecastle.com

Safety Information



These symbols are intended to alert the user to the presence of important operating and maintenance instructions in the manual accompanying the appliance.

To prevent an electric shock hazard, this device must be bonded to equipment in close proximity with an equipotential bonding conductor. This device is equipped with a grounding lug for this purpose and is marked with the following symbol.



CAUTION

This equipment is designed and sold for commercial use only by personnel trained and experienced in its operation and is not sold for consumer use in and around the home nor for use directly by the general public in food service locations.

WARNING

DO NOT CONNECT THE UNIT TO ANY TYPE OF VOLTAGE OTHER THAN THAT ON THE NAMEPLATE. DOING SO WILL DAMAGE THE UNIT AND VOID THE WARRANTY.

Electrical Specifications

Volts	Hz	Watts
230	50/60	2600

Model Number

Model	Description
CG14G-2TP	Grooved Platens, Split Top, 6-20 Plug

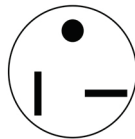

6-20P Plug for Unit

Installation

CAUTION

Before using your new equipment, read and understand all the instructions and labels associated with the unit prior to putting it into operation. Make sure all people associated with its use understand the unit's operation and safety before they use the unit.

1. All shipping containers should be checked for freight damage both visible and concealed. This unit has been tested and carefully packaged to insure delivery of your unit in perfect condition. If equipment is received in damaged condition, either apparent or concealed, a claim must be made with the delivering carrier.

NOTE: Concealed damage or loss – if damage or loss is not apparent until after equipment is unpacked, a request for inspection of concealed damage must be made with carrier within 15 days. Be certain to retain all contents plus external and internal packaging materials for inspection. The carrier will make an inspection and will supply necessary claim forms.

2. This sandwich grill is equipped for the voltage shown on the nameplate. It will operate on alternating current only, however the specified voltage must be applied.

WARNING

DO NOT CONNECT THE UNIT TO ANY TYPE OF VOLTAGE OTHER THAN THAT ON THE NAMEPLATE. DOING SO WILL DAMAGE THE UNIT AND VOID THE WARRANTY.

DAMAGED POWER CORDS MUST BE REPLACED BY THE MANUFACTURER, ITS SERVICE AGENT OR SIMILARLY QUALIFIED PERSONS IN ORDER TO AVOID A HAZARD.

Prince Castle reserves the right to change specifications and product design without notice. Such revisions do not entitle the buyer to corresponding changes, improvements, additions or replacements for previously purchased equipment.

Initial Start-Up

1. Level unit using the adjustable feet under the unit (approximately 1/2" adjustment).
2. Before using the unit for the first time, wipe down the exterior and toasting area with a damp cloth.
3. Take to a well ventilated area and heat for approximately 30 minutes.

NOTE: The grill may emit a small amount of smoke as the cooking surfaces reach 395°F(202°C). Do not be alarmed, as the smoke is caused by oils associated with the manufacturing process and will stop when the burn off is complete.

4. Brush off any debris from the toasting surface.

Seasoning the Cooking Surfaces (Non Chrome Surfaces)

First Time Seasoning

Follow your company/corporate guidelines for seasoning cooking surface, or

1. Bring the grill to 300°F (149°C) and leave it on while doing the next three steps.
2. Brush the cooking surfaces with a release agent. If using an aerosol agent, first apply into a cup and then brush onto cooking surface.
3. Let sit for 20 minutes, and then wipe clean using a warm damp cloth.

Daily Seasoning

The grill should not require much seasoning while in use. In most cases, brushing a light coating of the release agent in the morning and occasionally throughout the day will be enough to prevent any sticking. It is not necessary to brush before grilling each item.

Operating Instructions

Cooking Instructions

1. Start up the unit by placing the power switch into the ON position. The "heat on" indicator, located above the TEMP button, and the letters "lo" will display in the window. This indicates the unit is in a warm-up mode. When the preset platen temperatures are reached, the "heat on" indicator will turn off, the displays will stop flashing, and the unit will beep three times.

NOTE: Initial warm-up time is approximately 30 minutes.

2. Place a food product on the cooking surface and close the corresponding lid.
3. Press the product button for this food product and then press the button a second time, starting the cook timer that is shown on the display. When the cook timer countdown reaches "0" the unit will beep and the display will flash. Any timing cycle can be cancelled by simply pressing the product button again.
4. To turn off the beeper, press the product button. The display will stop flashing.
5. Raise the lid until it engages the first detent position which holds the lid up. Using an appropriate utensil, remove the cooked food product.

NOTE: The use of non-metallic utensils is recommended and will prolong the life of the cooking surfaces. However, metal utensils with rounded corners may be used.

6. Using a spatula, scrape any residue on the cooking surface into the center grease tray. Tray should be emptied and cleaned daily. Do not let food residue constantly sit on the cooking surface as food buildup will increase sticking and smoking. In addition, carbon may accumulate on the cooking surfaces and reduce the cooking efficiency.

NOTE: When not in use it is recommended that the lids be closed to prevent heat loss and save energy.

7. At store closing, turn the unit off by placing the power switch into the OFF position.

To Switch Between °F and °C

With the power switch in the OFF position, press and hold the left TEMP button while turning the power switch ON. The display will change to the opposite temperature mode. To change back enter password 4,3,2, 1, repeat this process.

Programming Instructions

Product cook times and platen set point temperatures can be adjusted in programming mode. While in programming mode, if no button is pressed for a period of 15 seconds, the unit will automatically exit programming mode and return to normal operation.

NOTE: Set point temperatures for both right and left side products are programmed ONLY from the left display (i.e., setting the temperature for product 2 on the left display will also be the temperature for product 2 on the right display).

Product Programming — Left Side

- A. For approximately 1 second, press and hold the TEMP button on the left display while at the same time pressing the product button to program (see Figure 1). The display window will show “- - - -”. Enter the password 4,3,2,1 (password numbers will not appear on the display). The display window will then show the current preset cook time and the selected product LED will flash.
- B. Press the UP(1) and DOWN(2) arrow buttons to adjust the cook time.
- C. Press the TEMP button to save the new cook time value (see Figure 2). Afterwards, the current set point temperature will be displayed.
- D. Press the UP(1) or DOWN(2) arrow button to adjust the temperature.
- E. Press the TEMP button to save the setting.
- F. Programming of this product is complete. Press the TEMP button again to exit programming mode or repeat steps B through E to make additional changes to this product.

Product Programming — Right Side (time only)

- A. For approximately 1 second, press and hold the TEMP button on the right display while at the same time pressing the product button to program. The display window will show “- - - -”. Enter the password 4,3,2,1 (password numbers will not appear on the display). The display window will then show the current preset cook time and the selected product LED will flash.
- B. Press the UP(1) and DOWN(2) arrow buttons to adjust the cook time.
- C. Press the TEMP button to save the setting.
- D. Programming of this product is complete. Press the TEMP button again to exit programming mode or repeat steps B through C to make additional changes to this product.

Resetting to Factory Defaults

To revert all settings back to the original factory defaults:

- A. Turn the unit off.
- B. Press and hold both the TEMP button and the “3” button.
- C. Turn the unit back on and wait 5 seconds.
- D. Release the TEMP button and the “3” button.

NOTE: All previously saved settings are lost upon resetting the defaults! Use with caution.

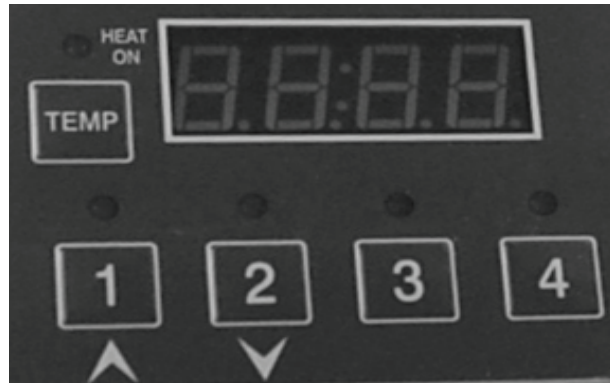

Figure 1

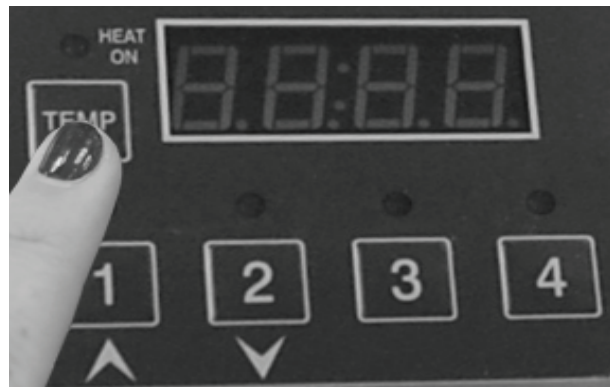

Figure 2

Monthly Inspection

Check all bolts/screws and tighten if necessary.

Cleaning

CAUTION

DO NOT IMMERSE OR LET THE UNIT STAND IN WATER. DO NOT HOSE DOWN THE UNIT. KEEP THE UNIT AWAY FROM RUNNING WATER.

DO NOT SPLASH THE CONTROL HOUSING! DO NOT SPLASH THE CONDUIT CONNECTING THE TOP AND BOTTOM OF THE GRILL! DO NOT USE ICE ON COOKING SURFACE!

Daily Operating Hours

1. After each cook cycle remove all grease and food residues from the cooking surfaces by scraping with a spatula. The spatula should have rounded corners to prevent the cooking surface from being scratched or marked.
2. Wipe cooking surface with a damp cloth if necessary to minimize grease buildup. If sticking begins to happen on a regular basis, apply a light coat of release agent as described in the "Seasoning the Cooking Surfaces" section of this manual.
3. Empty grease tray at least daily or as necessary during high use periods.

After Hours

1. When the unit is at operating temperature (minimum of 300°F [149°C]) press and hold the "4" button on the left display for 4 seconds to activate the cleaning mode. The display will flash "CLn" and "CLy" while the platens are cooling down and the "heat on" indicators will turn off. When the platen temperatures all reach 300°F (149°C), the display will show "CLn" and the unit will beep. Platen temperatures will hold at this level until the clean mode is cancelled by placing the power switch in the OFF position.

Platen Surface Limited Warranty Exclusions

Your two sided grill has been designed to give you many years of cooking reliability and requires minimum maintenance to keep the surface in its original condition. All platen surfaces are warranted for a period of 1 year against manufacturing defects to the original owner from the date of installation. This limited warranty is void if it is determined by Prince Castle or one of its authorized representatives that the platen surface has been misused or abused or subjected to the following situations:

1. Improperly installed.
2. Incorrect voltage applied to unit allowing the surface to overheat and discolor.

CAUTION

1. **Never** use pumice, griddle stones, or abrasives on platen surface.
2. **Never** strike the griddle surface with a sharp instrument or spatula edge.
3. **Never** use steel wool.
4. **Never** use commercial liquid grill cleaner on the griddle surface.
5. **Abusing** surface voids the warranty.

2. While in the clean mode, remove burned on grease by applying Sizzle Plus™ or a cleaning mixture consisting of 1 Tablespoon liquid dish detergent + 1 Cup of warm water to the cooking surfaces with a sponge or plastic scrubbing pad (remember, cooking surfaces are still hot).
3. Rinse surfaces with a clean damp sponge or cloth.
4. Repeat as necessary.
5. Apply a light coat of release agent as described in the "Seasoning the Cooking Surfaces" section of this manual.
6. Use a clean cloth and good nonabrasive cleaner to clean all *non-cooking* surfaces including the front displays. Wipe all surfaces with a soft cloth.
7. To remove carbon buildup (a black matter resulting from burnt on food residue, oils, and release agents) from the cooking surfaces, use an approved carbon removal agent (aluminum safe) applied in accordance with the instructions provided with the agent. After this process the cooking surfaces will need to be re-seasoned according to the instructions in the "Seasoning the Cooking Surfaces" section of this manual.

Platen Temperature Calibration

This process is necessary only when a platen temperature reading on the grill display varies more than a few degrees from the reading of a calibrated pyrometer used to measure the temperature of the same platen. The grill is calibrated before leaving the factory so this process should only be necessary on rare occasions.

1. Turn off the power switch. Press and hold both the UP(1) and DOWN(2) arrow buttons on the left display while the power switch is turned on (see Figure 3). Input the passwords, then the display will show "SET."
2. Press and release the TEMP button on the left display. The left display will alternate between the top left platen temperature and "T1". Press either the UP or DOWN button to change the displayed temperature to match the reading from the pyrometer (max adjustment is $\pm 27^{\circ}\text{F}$ [$\pm 15^{\circ}\text{C}$]).
3. Once the left platen has been adjusted, press and release the TEMP button on the left display again (see Figure 4). The left display will alternate between the top right platen temperature and "T2". Press either the UP or DOWN button to change the displayed temperature to match the reading from the pyrometer.
4. Once the right platen has been adjusted, press and release the TEMP button on the left display again. The left display will alternate between the bottom platen temperature and "T3". Press either the UP or DOWN button to change the displayed temperature to match the reading from the pyrometer. "T3" is the left bottom platen temperature. "T4" is the right bottom platen temperature.
5. Press the TEMP button on the right display or turn off the power switch to save the new settings.

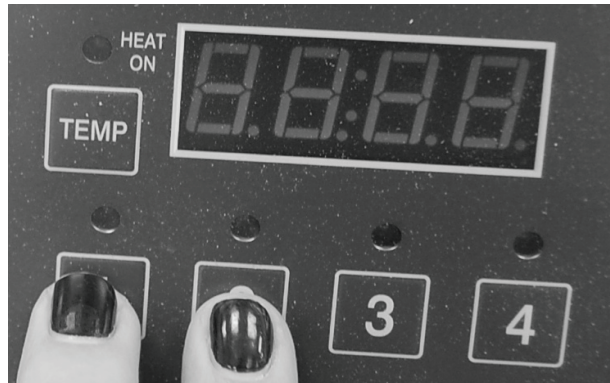

Figure 3

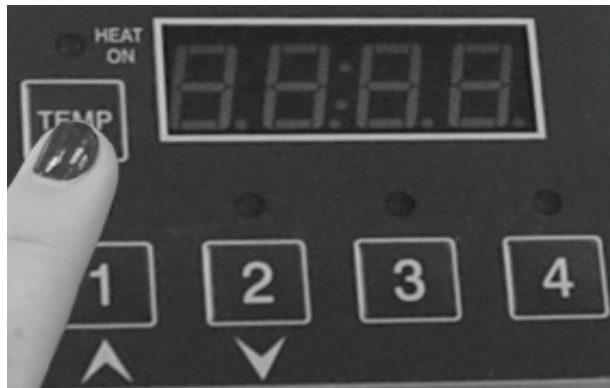
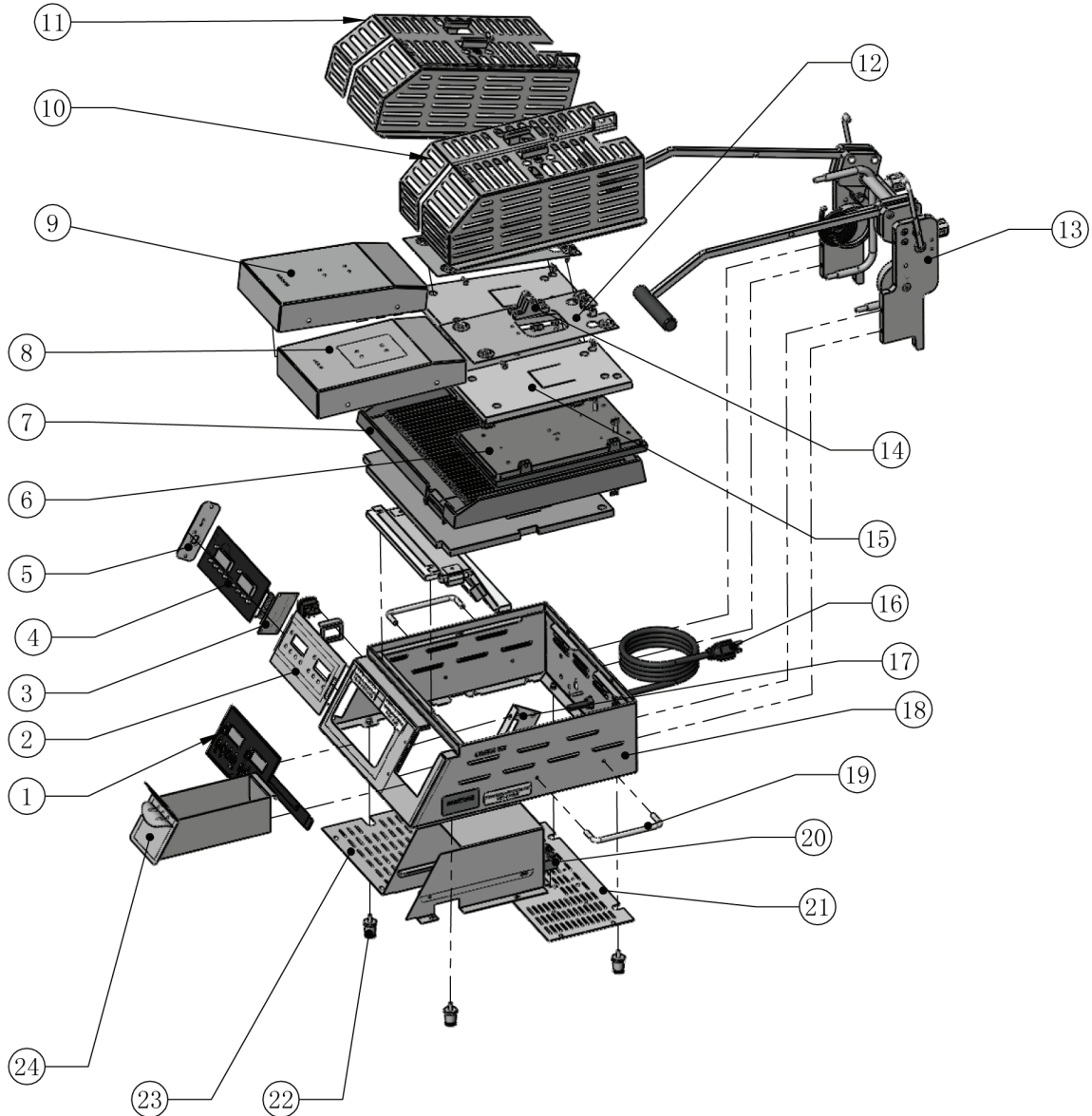

Figure 4

Exploded View



Ref.	Part No.	Description	Ref.	Part No.	Description
1	CG-521	Overlay	16	CG-567	Power Cord
2	CG-516	Assy PCB Brk	17	CG-520	Connect PCB Brk
3	CG-531	Connect PCB	18	CG-527	Body
4	CG-530	Main PCB	19	CG-204	Handle
5	CG-537	PCB Cover	20	65-058	Relay P/N84134020
6	CG-141	Machined, Upper Grill	21	CG-529	Assy Panel Door
7	CG-506	Machined, Lower Grill	22	86-255/CG-900	Leg, 1"H1, 1/4-20MTG Stud
8	CG-552	Assy Upper Right Cover	23	CG-535	Cabing Grease Trap
9	CG-553	Assy Upper Left Cover	24	CG-517	Grease Tray
10	CG-566	Assy Right Protect Plate			
11	CG-564	Assy Left Protect Plate			
12	CG-009	Back Plate, Upper Heater			
13	CG-104	Counter Balance			
14	CG-013	Upper Platen Hanger			
15	CG-012	Insulation Upper			

