



IDC PRO 255

Operator's Manual



Release Date: MAR, 08 2017

Publication Number: 621058649OPR

Revision: A

Revision Date: MAR, 08 2017

Visit the Cornelius web site at www.cornelius-usa.com for all your Literature needs.

The products, technical information, and instructions contained in this manual are subject to change without notice. These instructions are not intended to cover all details or variations of the equipment, nor to provide for every possible contingency in the installation, operation or maintenance of this equipment. This manual assumes that the person(s) working on the equipment have been trained and are skilled in working with electrical, plumbing, pneumatic, and mechanical equipment. It is assumed that appropriate safety precautions are taken and that all local safety and construction requirements are being met, in addition to the information contained in this manual.

This Product is warranted only as provided in Cornelius' Commercial Warranty applicable to this Product and is subject to all of the restrictions and limitations contained in the Commercial Warranty.

Cornelius will not be responsible for any repair, replacement or other service required by or loss or damage resulting from any of the following occurrences, including but not limited to, (1) other than normal and proper use and normal service conditions with respect to the Product, (2) improper voltage, (3) inadequate wiring, (4) abuse, (5) accident, (6) alteration, (7) misuse, (8) neglect, (9) unauthorized repair or the failure to utilize suitably qualified and trained persons to perform service and/or repair of the Product, (10) improper cleaning, (11) failure to follow installation, operating, cleaning or maintenance instructions, (12) use of "non-authorized" parts (i.e., parts that are not 100% compatible with the Product) which use voids the entire warranty, (13) Product parts in contact with water or the product dispensed which are adversely impacted by changes in liquid scale or chemical composition.

Contact Information:

To inquire about current revisions of this and other documentation or for assistance with any Cornelius product contact:

www.cornelius.com
800-238-3600

Trademarks and Copyrights:

This document contains proprietary information and it may not be reproduced in any way without permission from Cornelius.

This document contains the original instructions for the unit described.

CORNELIUS INC
101 Regency Drive
Glendale Heights, IL
Tel: + 1 800-238-3600

Printed in U.S.A.

Correct Disposal of this Product



RECYCLE

This marking indicates that this product should not be disposed with other household wastes throughout the EU. To prevent possible harm to the environment or human health from uncontrolled waste disposal, recycle it responsibly to promote the sustainable reuse of material resources. To return your used device, please use the return and collection systems or contact the retailer where the product was purchased. They can take this product for environmental safe recycling.

TABLE OF CONTENTS

Safety Instructions	1
Read and Follow ALL Safety Instructions	1
Safety Overview	1
Recognition	1
Different Types of Alerts	1
Safety Tips	1
Qualified Service Personnel	2
Safety Precautions	2
Shipping And Storage	2
CO ₂ (Carbon Dioxide) Warning	2
Unit Location	3
System Overview	4
Features	4
Specifications	4
Operation	6
Starting the Unit	6
Initial Power Up	6
ADA Keypad Operation	7
Cleaning and Maintenance	8
Daily Cleaning and Maintenance	8
Daily Inspection	8
Checking the CO ₂ Supply	8
Checking for CO ₂ and Water Leaks	8
Daily Cleaning	9
Weekly Cleaning and Maintenance	12
Cleaning the Splash Panels and the Drip Tray Cover	12
Monthly Cleaning and Maintenance	14
Syrup Line Cleaning & Sanitizing	14
Cleaning and Sanitizing the Hopper	15
Quarterly Cleaning and Maintenance	16
Cleaning and Sanitizing the Cold Plate	16
Annual Cleaning and Maintenance	17
Annual Inspection	17
Maintenance Procedures	18
General	18
Unit Operation	18
Unit Shutdown/Restart	18
Changing to a Different Brand or Flavor	19
Replenishing the CO ₂ Supply	20
Service Mode	20
Mapping Brands	22
Purging The Syrup Lines	24
Syrup Line Cleaning & Sanitizing	25
Adjusting the Water to Syrup Ratio (BRIX)	26
Cleaning Interior Surfaces	29
Updating Software Revisions	31
Editing the Media Play-list	33
Reporting Sales Data	37

SAFETY INSTRUCTIONS

READ AND FOLLOW ALL SAFETY INSTRUCTIONS

Safety Overview

- Read and follow **ALL SAFETY INSTRUCTIONS** in this manual and any warning/caution labels on the unit (decals, labels or laminated cards).
- Read and understand ALL applicable OSHA (Occupational Safety and Health Administration) safety regulations and/or national and local codes before operating this unit.

Recognition

Recognize Safety Alerts
 <p>This is the safety alert symbol. When you see it in this manual or on the unit, be alert to the potential of personal injury or damage to the unit.</p>

Different Types of Alerts

DANGER:

Indicates an immediate hazardous situation which, if not avoided, **WILL** result in serious injury, death or equipment damage.

WARNING:

Indicates a potentially hazardous situation which, if not avoided, **COULD** result in serious injury, death, or equipment damage.

CAUTION:

Indicates a potentially hazardous situation which, if not avoided, **MAY** result in minor or moderate injury or equipment damage.

SAFETY TIPS

- Carefully read and follow all safety messages in this manual and safety signs on the unit.
- Keep safety signs in good condition and replace missing or damaged items.
- Learn how to operate the unit and how to use the controls properly.
- **Do not** let anyone operate the unit without proper training. This appliance is **not** intended for use by very young children or infirm persons without supervision. Young children should be supervised to ensure that they do not play with the appliance.
- Keep your unit in proper working condition and do not allow unauthorized modifications to the unit.

QUALIFIED SERVICE PERSONNEL

WARNING:

Only trained and certified electrical, plumbing and refrigeration technicians should service this unit. **ALL WIRING AND PLUMBING MUST CONFORM TO NATIONAL AND LOCAL CODES. FAILURE TO COMPLY COULD RESULT IN SERIOUS INJURY, DEATH OR EQUIPMENT DAMAGE.**

SAFETY PRECAUTIONS

This unit has been specifically designed to provide protection against personal injury. To ensure continued protection, observe the following:

WARNING:

Disconnect power to the unit before servicing following all lock out/tag out procedures established by the user. Verify all of the power is off to the unit before any work is performed.

Failure to disconnect the power could result in serious injury, death or equipment damage.

CAUTION:

Always be sure to keep area around the unit clean and free of clutter. Failure to keep this area clean may result in injury or equipment damage.

SHIPPING AND STORAGE

CAUTION:

Before shipping, storing, or relocating the unit, the unit must be sanitized and all sanitizing solution must be drained from the system. A freezing ambient environment will cause residual sanitizing solution or water remaining inside the unit to freeze resulting in damage to internal components.

CO₂ (CARBON DIOXIDE) WARNING

DANGER:

CO₂ displaces oxygen. Strict attention **MUST** be observed in the prevention of CO₂ gas leaks in the entire CO₂ and soft drink system. If a CO₂ gas leak is suspected, particularly in a small area, **IMMEDIATELY** ventilate the contaminated area before attempting to repair the leak. Personnel exposed to high concentrations of CO₂ gas experience tremors which are followed rapidly by loss of consciousness and **DEATH**.

UNIT LOCATION

 **CAUTION:**

The unit is not designed for a wash-down environment and **MUST NOT** be placed in an area where a water jet (pressure washer) could be used.

 **CAUTION:**

This appliance is not intended for use by personnel (including children) with reduced physical, sensory or mental capabilities or lack of experience and knowledge, unless given supervision or instruction concerning use of the appliance by a person responsible for safety.

SYSTEM OVERVIEW

The Refresh IDC PRO 255 unit solves your ice and beverage service needs in a sanitary, space saving, economical way. It is designed to be manually filled with ice from any remote ice making source. The unit distributes cubes (up to 1-1/4 inch in size), cube-lets and compressed (not flaked) ice. Also, the unit includes beverage valves and cold-plate.

CAUTION:

The unit cannot be used with crushed or flaked ice. Use of bagged ice which has frozen into large chunks can void warranty. The unit agitator is not designed to be an ice crusher. Use of large chunks of ice which “jam up” inside the hopper will cause failure of the agitator motor and damage to the hopper. If bagged ice is used, it must be carefully and completely broken into small, cube-sized pieces and left to “temper” or warm up for a minimum of 20 minutes in room temperature before loading into the unit hopper.

FEATURES

- Brand density - 10 brands on each side, 7 chilled, 3 ambient and up to 8 flavor shots (4 per side) for over 320 drink combinations.
- Large HD merchandising display.
- 255 lb. capacity ice cube hopper.
- Dispenses cubed or chew-able soft ice

SPECIFICATIONS

Table 1.

Model	IDC Pro 255
Maximum Number of Valves available	32 Total; 20 brands, 8 flavors & 4 water
Built-in Cold Plate	Yes
Voltage	120 V 60 Hz, single phase; 8.5A. of total unit draw 220 -240V 50 - 60Hz, single phase; 5.5A of total unit draw
Height	39-3/16 in. (.955 m) to top of Adapter lid
Depth	32-3/8 in. (0.823 m)
Width	30 in. (0.762 m)
Screen Dimensions	32 in. Diagonally
CO ₂ Operating Pressure for brand	65 psig (5.17 bar) minimum
CO ₂ Operating Pressure for flavor	30-45 psig (2.07-3.10 bar)
Water Pressure	60 psig (3.45-4.48 bar) minimum
Water Volume	Minimum flow rate, 125 gal/hr. (0.473 cubic meters/hr.)
Shipping Weight	545 lb. (247.2 kg)
Counter Weight	440 lb. (199.6 kg)
Ice Storage Weight	255 lbs. (115.7 kg)
Cup Clearance	9-3/4 in. (24.77 cm)
Ambient Operating Temperature	65 to 95° F (18.3 to 35° C)

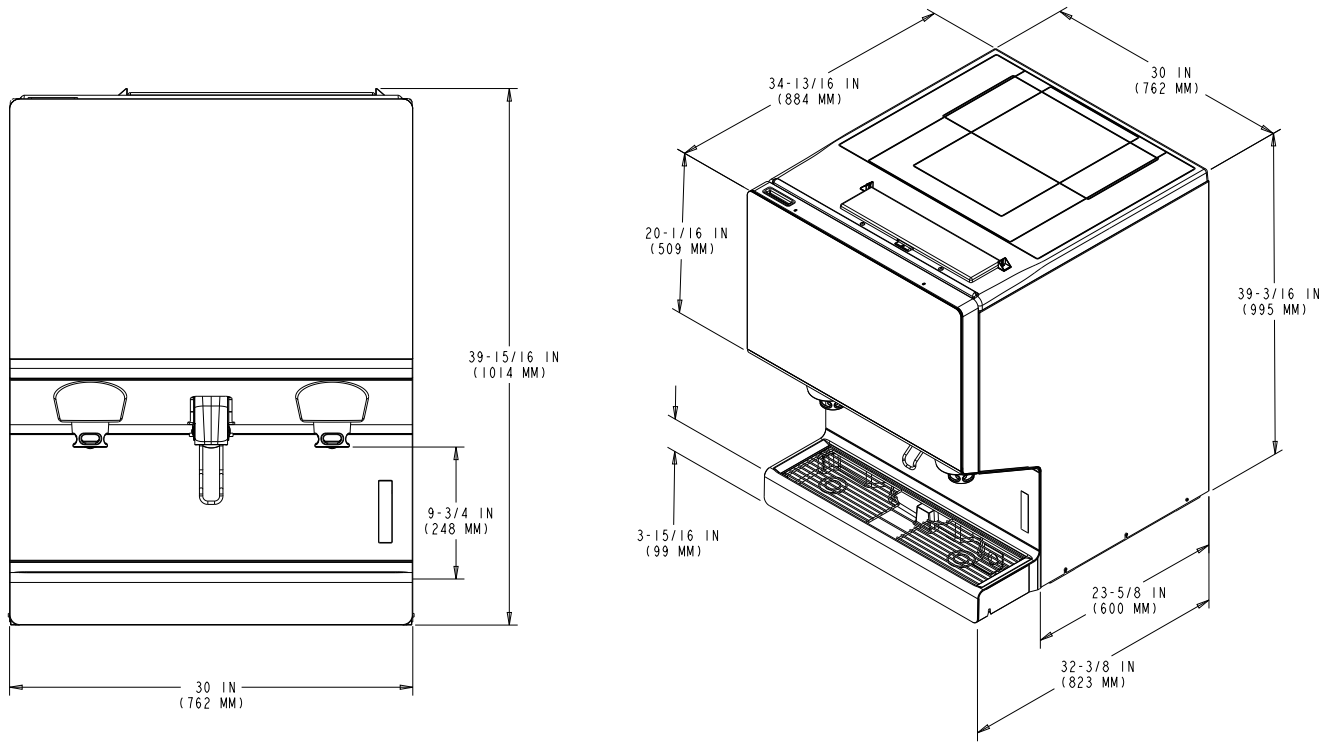

Figure 1.

OPERATION

WARNING:

Only trained and certified electrical, plumbing and refrigeration technicians should service this unit.

ALL WIRING AND PLUMBING MUST CONFORM TO NATIONAL AND LOCAL CODES. FAILURE TO COMPLY COULD RESULT IN SERIOUS INJURY, DEATH OR EQUIPMENT DAMAGE.

STARTING THE UNIT

Fill the hopper with ice or allow the ice maker to fill. Dispense several large cups of ice (approximately 20 to 30 seconds total dispensing time) to allow ice to fill the cold plate cabinet. Add ice to the hopper as necessary to refill, then replace the lid for manual ice units. Allow 10 to 15 minutes for the cold plate to cool down. Repeat this procedure whenever the unit has run out of ice. Contact your local syrup distributor for complete information on the beverage syrups.

CAUTION:

Do not allow the unit to be stored or operated in conditions below 32° F (0° C). This could cause damage to the unit.

In normal operation, pushing the ice dispenser mechanism causes ice to flow from the ice chute. Ice flow continues until the dispenser mechanism is released. Dispensing from any valve provides a beverage of the appropriate flavor.

WARNING:

Use caution to avoid spilling ice when filling the unit. Clean up immediately any spilled ice from filling or operating the unit. To prevent contamination of ice, the lid must be installed on the unit at all times. Failure to clean up spills could result in serious injury or death.

If the unit fails to dispense ice or beverage, refer to the troubleshooting section in the Installation Manual part number 621058649INS.

Initial Power Up

The first time the unit is powered up, the power must be plugged into the proper wall outlet (120 V 60 Hz, single phase). The unit must be connected to a protected 15A. outlet.

ADA KEYPAD OPERATION

The ADA keypad is located on the lower right side of the splash panel. The ADA keypad, shown in Figure 2 illuminates when the ADA activation button is selected.

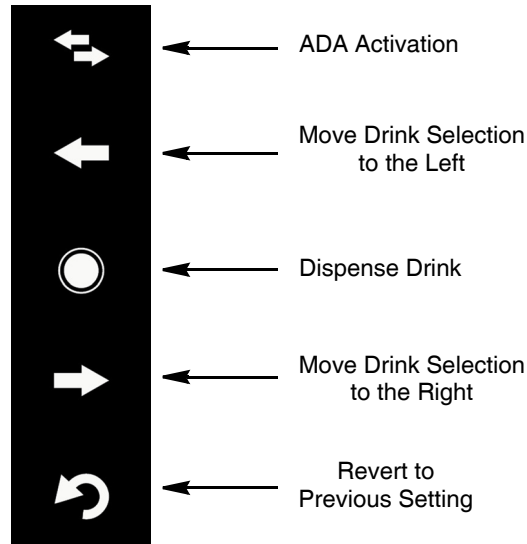

Figure 2.

CLEANING AND MAINTENANCE

WARNING:

Disconnect power to the unit before servicing. Follow all lock out/tag out procedures established by the user. Verify all power is off to the unit before performing any work.

Failure to comply could result in serious injury, death or damage to the equipment.

CAUTION:

Do not use metal scrapers, sharp objects or abrasives on the ice storage hopper, top cover, agitator disc or exterior surfaces as damage to the unit may result. Do not use solvents or other cleaning agents as they may attack the material resulting in damage to the unit.

Soap solution - Use a mixture of mild detergent and warm (100° F) potable water.

Sanitizing Solution - Dissolve 1 packet [1 oz. (29.5 ml)] of KAY-5 into 2-1/2 gallons (9.5 l) of warm 80 - 100° F (26.7 - 37.8° C) potable water to ensure 100 ppm of chlorine.

DAILY CLEANING AND MAINTENANCE

For proper operation of the unit, it must be inspected and cleaned on a daily basis.

Daily Inspection

1. Check the water supply valves.
2. Visually check the beverage/syrup lines for leaks. If leaks are noted, call a service technician.
3. Check the temperature, smell and taste of the product.
4. Check the carbonation of the drinks.
5. Check the level of the CO₂ supply in the backroom.
6. Check the dates on all the BIB for expiration.
7. Remove foreign material from vending area drip tray to prevent drain blockage
8. Clean vending area. Check for proper water drainage from the drip tray.

Checking the CO₂ Supply

Make sure the bulk CO₂ cylinder regulator gage indicator is not in the shaded (“change CO₂ cylinder”) portion of the dial. If the gage indicator is in the shaded area, the cylinder is almost empty and must be replaced.

Checking for CO₂ and Water Leaks

Check the unit for CO₂ and water leaks. If any are found, call a qualified service technician to repair them, as needed.

Daily Cleaning

To perform a daily cleaning of the unit, perform the procedure as shown in Table 2.

Table 2.

Step	Action	
1	Remove the cup rest from the drip tray and clean it with warm soapy water, rinse it with clean water and allow it to air dry.	 <p style="text-align: center;">Figure 3.</p>
2	Display the keypad screen by tapping each corner of the video screen starting in the upper right corner (1) and continuing to tap each corner in a counterclockwise direction, in a sequence of 1,2,3 and 4 as shown in Figure 4 NOTE: As each corner is touched, a small confirmation rectangle may momentarily appear to confirm the touch.	 <p style="text-align: center;">Figure 4.</p>
3	Input the proper password for your access level (operator) and press enter.	 <p style="text-align: center;">Figure 5.</p>

Table 2.



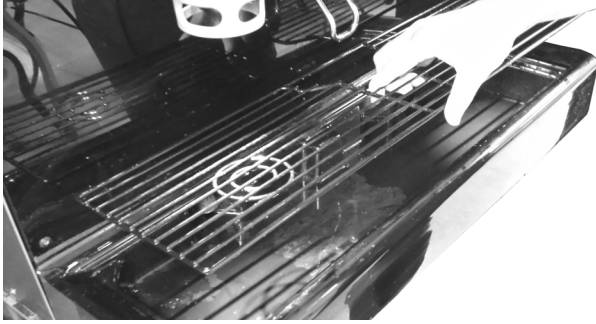
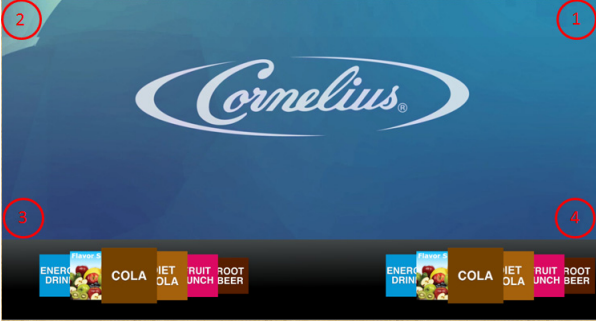
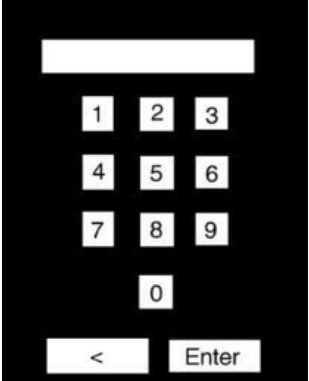

Step	Action	
4	<p>Select the Screen Cleaning lockout button to display the Screen Cleaning Screen, as shown Figure 6. Touch the screen to start the countdown for cleaning as shown Figure 7. This function disables the display so that drinks are not dispensed during the screen cleaning process.</p>	 <p style="text-align: center;">Figure 6.</p>  <p style="text-align: center;">Figure 7.</p>
5	<p>Wipe down the display screen while the countdown timer is disabling the display.</p>	
6	<p>When the display screen is clean, touch the Back button in the lower right corner of the screen.</p>	
7	<p>Wipe down the rest of the exterior of the unit with warm soapy water, rinse it with clean water and allow it to air dry.</p>	
8	<p>Remove the nozzles and diffusers by rotating anti-clockwise direction as shown in Figure 8. and wash them in warm soapy water. Clean with nylon bristle brush provided, if required. Rinse the nozzles and diffusers in clean water and allow them to air dry.</p> <p>NOTE: Do not soak for more than 2 minutes.</p>	 <p style="text-align: center;">Figure 8.</p>  <p style="text-align: center;">Figure 9.</p>

Table 2.

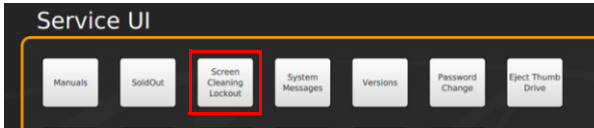

Step	Action	
9	Reinstall the diffuser by pushing it vertically upward by aligning the key-slot as shown in Figure 10.	 <p data-bbox="906 693 1024 722">Figure 10.</p>
10	Re-install the nozzle in the unit by rotating it in clockwise direction as shown in the Figure 11. NOTE: Do not cross thread the nozzle.	 <p data-bbox="906 1157 1024 1186">Figure 11.</p>
11	Clean the interior of the ice chute using the brush provided with the unit. User warm soapy water, rinse with clear water and allow to air dry.	 <p data-bbox="906 1713 1024 1743">Figure 12.</p>

Table 2.

Step	Action	
12	Spray the ice chute inside and out with sanitizer and allow it to air dry.	 <p data-bbox="808 667 927 695">Figure 13.</p>
13	Pour warm soapy water down the drain to keep it clean and flowing properly.	
14	Spray the nozzles and diffusers inside and outside with approved sanitizing solution, reinstall them on the valves and allow them to air dry.	
15	Reinstall the cup rest into the drip tray.	
16	Pour all the remaining sanitizer solution down the drain to help keep the drain clear.	

WEEKLY CLEANING AND MAINTENANCE

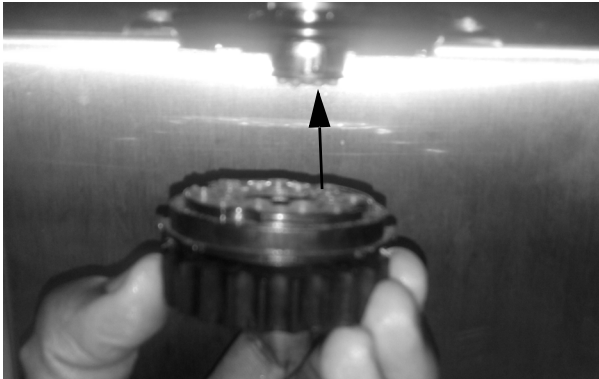
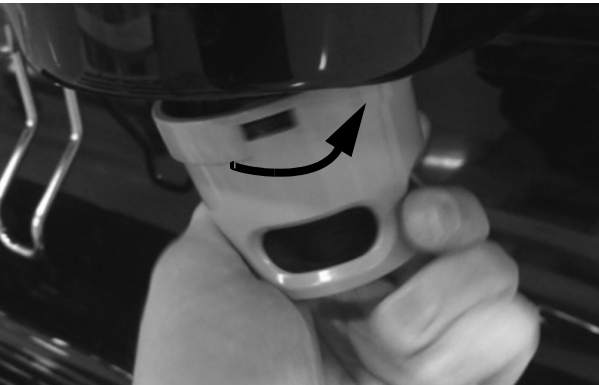
Perform the daily cleaning procedure in addition to the weekly cleaning procedures in the following sections.

The weekly cleaning procedures are:

- Daily Cleaning and Maintenance
- Cleaning the Splash Panels and Drip Tray Cover.

Cleaning the Splash Panels and the Drip Tray Cover

To clean the splash panels and the drip tray cover, perform the procedure as shown in Table 3.

Table 3.

Step	Action	
1	Remove the cup holder from the unit as shown in Figure 14.	 <p data-bbox="797 1850 915 1877">Figure 14.</p>

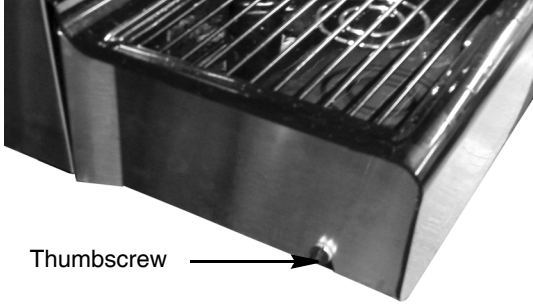
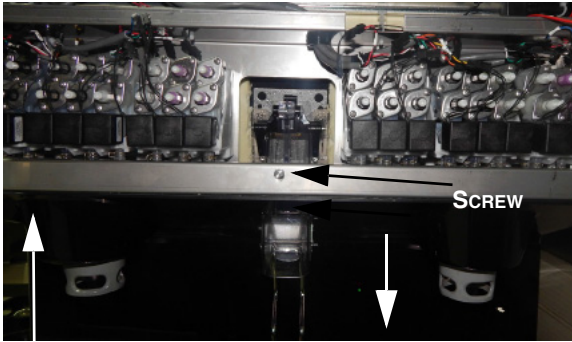
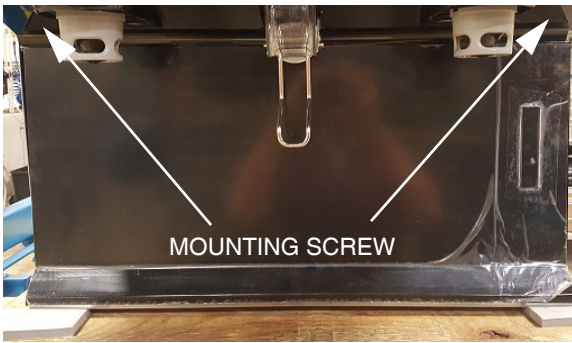
<p>2</p>	<p>Loosen the thumbscrews on both sides of the drip tray cover.</p>	 <p>Thumbscrew →</p> <p>Figure 15.</p>
<p>3</p>	<p>Remove the drip tray cover from the unit.</p>	
<p>4</p>	<p>Wipe down the cup holder and drip tray cover with warm soapy water, rinse them with clear water and allow them to air dry.</p>	
<p>5</p>	<p>Open the display panel and remove the thumb-screw holding the upper splash panel as shown in Figure 16 and pull the panel forward and down to remove it.</p>	 <p>← SCREW</p> <p>↑ Upper Splash panel ↓ Pull downwards</p> <p>Figure 16.</p>
<p>6</p>	<p>Remove the two screws from the top two corners of the splash panel as shown in Figure 17, slide the panel upward to disengage the two bottom tabs and pull the splash panel forward to remove it.</p>	 <p>MOUNTING SCREW</p> <p>Figure 17.</p>
<p>7</p>	<p>Wipe down the splash panels with warm soapy water, rinse them with clear water and allow them to air dry.</p>	
<p>8</p>	<p>Replace the splash panels, the drip tray cover and the cup holder onto the unit.</p>	

MONTHLY CLEANING AND MAINTENANCE

Perform the daily and weekly cleaning procedures in addition to the monthly cleaning procedures in the following sections.

The monthly cleaning procedures are:

- Daily Cleaning and Maintenance
- Weekly Cleaning and Maintenance
- Syrup Line Cleaning and Sanitizing
- Cleaning the Hopper

Syrup Line Cleaning & Sanitizing

CAUTION:

Only trained and qualified persons should perform these cleaning and sanitizing procedures.

To sanitize the tubing and BIB connectors, perform the procedure as shown in Table 4.

Table 4.

Step	Action
1	Remove all the quick disconnects from all the BIB containers.
2	Fill a suitable bucket with a soap solution.
3	Submerge all disconnects (gas and liquid) in the soap solution and then clean them using a nylon bristle brush. (Do not use a wire brush.) Rinse with clean, potable water.
4	Using a plastic pail, prepare approximately 5 gallons (18.93 l) of sanitizing solution.
5	Rinse the BIB disconnects in the sanitizing solution.
6	Sanitizing fittings must be attached to each BIB disconnect. If the fittings are not available, the fittings from empty BIB bags can be cut from the bags and used. These fittings open the disconnects so the sanitizing solution can be drawn through the disconnect.
7	Place all the BIB disconnects into the pail of sanitizing solution. Open the valves and allow them to flow until sanitizer is flowing from the valves. Allow the sanitizer to remain in the tubing lines for 15 minutes.
8	Remove all the nozzles and syrup diffusers and clean them in a mild soap solution, rinse them with clean water and reassemble the nozzles and syrup diffusers onto the valves.
9	Remove the sanitizing fittings from the BIB disconnects and connect the disconnects to the appropriate BIB container.
10	Open the valves and let sanitizer flow until all the sanitizer has been flushed from the system and only syrup is flowing.

To clean the hopper, perform the procedure as shown in Table 5.

Table 5.

Step	Action
1	Remove all the ice from the hopper. Clean and sanitize the hopper. See "Cleaning Interior Surfaces" section on page 29.
2	While cleaning the hopper, use the brush provided with the unit to clean the cold plate surface. To accomplish this, the brush needs to be extended through the opening in the bottom of the hopper.

Cleaning and Sanitizing the Hopper



As part of the monthly cleaning procedures, clean the hopper by performing the procedure as shown in Table 6.



CAUTION:

When pouring liquid into the hopper, do not exceed the rate of 1/2 gallon per minute. Pouring liquid into the hopper faster than the recommended rate could result in an overflow situation which may result in personal injury or damage to the equipment.

Table 6.

Step	Action	
1	Remove the top cover from the hopper or open the manual fill door on the ice maker (if equipped).	
2	Remove the agitator assembly by unscrewing the thumbscrew and lifting the agitator assembly out of the hopper as shown in Figure 18.	 <p>Figure 18.</p>
3	Using a cloth or sponge, clean the interior of the hopper, top cover and agitator assembly with soap solution. Thoroughly rinse the hopper, cover and agitator surfaces with clean potable water.	 <p>Figure 19.</p>
4	Re-assemble agitator assembly. Take special care to ensure that the thumbscrew is tight.	

5	Using a mechanical spray bottle filled with sanitizing solution, spray the entire interior and the agitator assembly. Allow them to air dry.	 <p style="text-align: center;">Figure 20.</p>
6	Replace the hopper cover or close the manual fill door on the ice maker (if equipped).	

QUARTERLY CLEANING AND MAINTENANCE

Perform the daily, weekly and monthly cleaning procedures in addition to the quarterly cleaning procedures in the following sections.

The quarterly procedures are:

- Daily Cleaning and Maintenance
- Weekly Cleaning and Maintenance
- Monthly Cleaning and Maintenance
- Cleaning and Sanitizing the Cold Plate

Cleaning and Sanitizing the Cold Plate

To clean the cold plate, perform the procedure as shown in Table 7.

Table 7.

Step	Action	
1	Remove power from the unit.	
2	Open the unit display.	
3	Remove the splash panel and the cold plate covers to expose the bottom of the cold plate.	 <p style="text-align: center;">Figure 21</p>

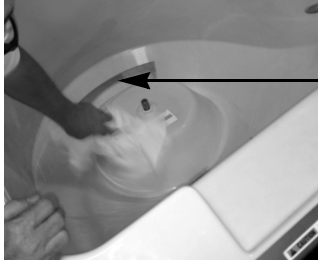
4	Locate and remove any debris from the drain trough. Check that the cold plate drain holes are not plugged.
5	<div style="display: flex; align-items: center;"> <div style="flex: 1;"> <p>Pour a small amount of warm soapy water through the upper cold plate openings in the hopper.</p> </div> <div style="flex: 1; text-align: center;">  <p>Figure 22.</p> </div> <div style="flex: 0.5; text-align: right; vertical-align: middle;"> <p>Cold Plate Access</p> </div> </div>
6	Using a clean, soft cloth, wash down the surfaces of the cold plate from the top and bottom with warm soapy water.
7	For manual ice units, wipe down the hopper cover with warm soapy water.
8	Rinse the cold plate with warm potable water. For manual ice units, also rinse the hopper cover with warm potable water.
9	Using a mechanical spray bottle filled with sanitizing solution, spray the upper and lower cold plate access areas and let the unit air dry.
10	Reinstall and position the access covers on the bottom of the cold plate.
11	Reinstall the splash panel.
12	Rinse the cold plate surface by pouring any left over sanitizing solution through the hopper opening.

ANNUAL CLEANING AND MAINTENANCE

Perform all of the annual procedures below in addition to the daily, weekly, monthly and quarterly procedures.

Annual Inspection

Remove the unit's splash and cold plate cover to clean and sanitize the cold plate surface. (See the cleaning the cold plate section shown later in this manual).

MAINTENANCE PROCEDURES

GENERAL

⚠ CAUTION:

Operators must not make any adjustments to the equipment without approval from a supervisor.

UNIT OPERATION

⚠ WARNING:

This unit must be grounded to avoid possible electrical shock to the operator. The unit power cord is equipped with a three pronged plug. If a three pronged (grounded) outlet is not available use an appropriate method to ground the unit.

Failure to comply could result in serious injury, death or damage to the equipment.

To initially start up the unit for operation, perform the procedure in Table 8.

Table 8.

Step	Action
1	Connect electrical power to the unit.
2	Check for water leaks, and tighten any loose connections.

UNIT SHUTDOWN/RESTART

The unit can be shutdown by entering the service UI at any level and selecting the “shutdown” icon. To shut down or restart the unit, perform the procedure in Table 9.

Table 9.

Step	Action
1	<p>Display the keypad screen by tapping each corner of the video screen starting in the upper right corner (1) and continuing to tap each corner in a counterclockwise direction, in a sequence of 1,2,3 and 4 as shown in Figure 23.</p> <p>NOTE: As each corner is touched, a small confirmation rectangle may momentarily appear to confirm the touch.</p>

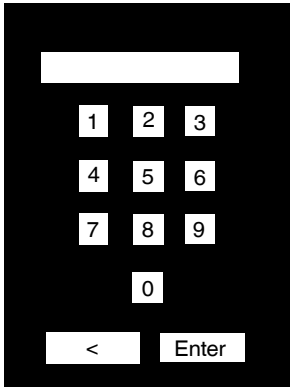
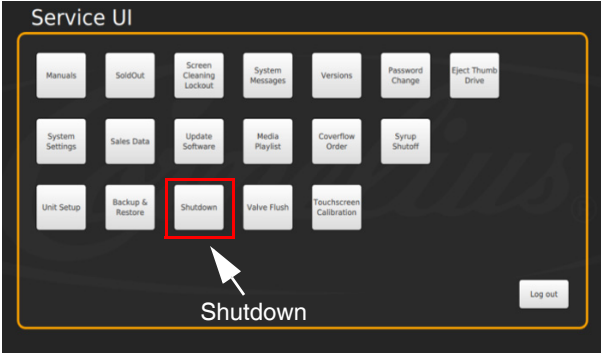
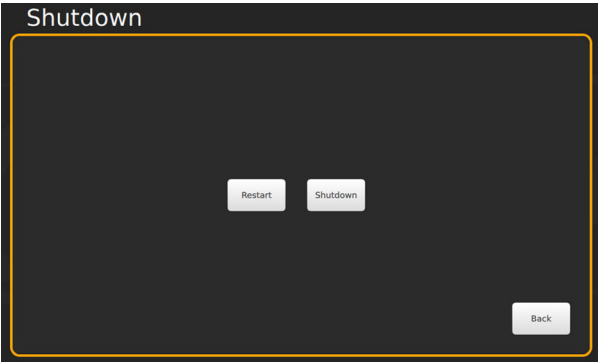

Figure 23.

Step	Action	
2	Input the proper password for your access level (technician) and press Enter.	 <p data-bbox="1110 648 1227 676">Figure 24.</p>
3	Select the Shutdown button to display the Shutdown/Restart Screen, as shown in Figure 25.	 <p data-bbox="1110 1125 1227 1152">Figure 25.</p>
4	Press the Shutdown button to start the shutdown process or press the Restart button to restart the unit as shown in Figure 26.	 <p data-bbox="1110 1554 1227 1581">Figure 26.</p>

CHANGING TO A DIFFERENT BRAND OR FLAVOR

When replacing or changing the BIB containers, clean and sanitize the syrup system, as described in “Syrup Line Cleaning & Sanitizing” section on page 14.

REPLENISHING THE CO₂ SUPPLY

⚠ DANGER:

CO₂ displaces oxygen. Strict attention **MUST** be observed in the prevention of CO₂ gas leaks in the entire CO₂ and soft drink system. If a CO₂ gas leak is suspected, particularly in a small area, **IMMEDIATELY** ventilate the contaminated area before attempting to repair the leak. Personnel exposed to high concentrations of CO₂ gas experience tremors which are followed rapidly by loss of consciousness and **DEATH**.

When indicator on the 1800 psi gauge is in the shaded (“change CO₂ cylinder”) portion of the dial, CO₂ cylinder is almost empty and should be changed.

To replenish the CO₂ supply, perform the procedure in Table 10.

Table 10.

Step	Action
1	Fully close (clockwise) the CO ₂ bulk cylinder valve.
2	Slowly loosen the CO ₂ regulator assembly coupling nut, allowing CO ₂ pressure to escape.
3	Then remove the regulator assembly from the empty CO ₂ cylinder.
4	Unfasten the safety chain and remove the empty CO ₂ cylinder.
5	Position the full CO ₂ cylinder and secure the cylinder with the safety chain.
6	Make sure the gasket is seated properly inside the CO ₂ regulator assembly coupling nut, then install the regulator assembly on the CO ₂ cylinder.
7	Open (counterclockwise) the CO ₂ cylinder valve slightly to allow the lines to slowly fill with gas, then open the valve fully to back-seat the it (back-seating the valve prevents gas leakage around the valve shaft).
8	Check CO ₂ connections for leaks. Tighten any loose connections.

SERVICE MODE

The Service mode is used to perform all of the maintenance and troubleshooting for the unit. There are three menu levels available depending on the classification of the operator. shows the service mode screen for operators, Figure 29 shows the service mode screen for supervisors and Figure 29 shows the service mode screen for service technicians. To enter the service mode, perform the procedure in Table 11.

Table 11.

Step	Action
1	<p>Display the keypad screen by tapping each corner of the video screen starting in the upper right corner (1) and continuing to tap each corner in a counterclockwise direction, in a sequence of 1,2,3 and 4 as shown in Figure 27.</p> <p>NOTE: As each corner is touched, a small confirmation rectangle may momentarily appear to confirm the touch.</p>

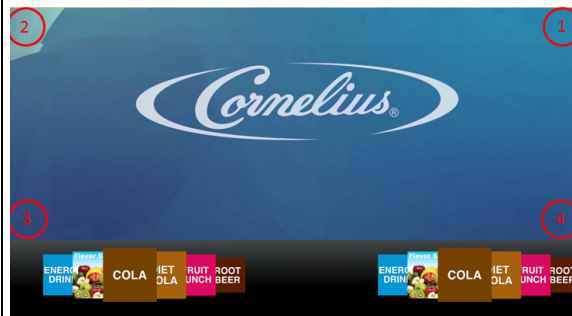
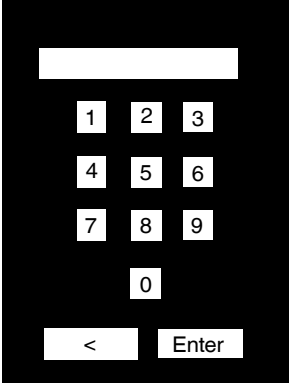

Figure 27.

Table 11.

Step	Action	
2	<p>Input the proper password for your access level (Operator, Store Manager or Technician) and press Enter. The Service UI screen is displayed, as shown in Figure 29 depending on your access level.</p> <p>NOTE: Each access level has a different password.</p>	 <p style="text-align: center;">Figure 28</p>

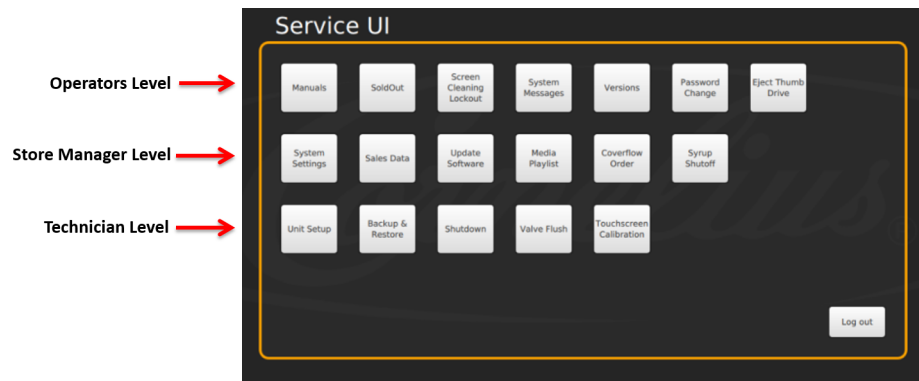

Figure 29.

The service screen has a few layout changes, however the access levels remain the same. You have the ability to change your default pass-codes.

- Row 1** of the service screen shows what will be displayed when the operators level pass-code is entered.
- Row 2** is displayed when the manager level pass-code is entered. This level has visibility to levels 1 and 2.
- Row 3** is displayed when the technician level pass-code is entered. This level has visibility to all 3 levels.

NOTE: The Shutdown button is available on all levels.

Mapping Brands

To map the valves to the available brands, perform the procedure as shown in Table 12.

Table 12.

Step	Action	
1	<p>Display the keypad screen by tapping each corner of the video screen starting in the upper right corner (1) and continuing to tap each corner in a counterclockwise direction, in a sequence of 1,2,3 and 4 as shown in Figure 30.</p> <p>NOTE: As each corner is touched, a small confirmation rectangle may momentarily appear to confirm the touch.</p>	 <p>Figure 30.</p>
2	<p>Input the proper password for your access level (technician) and press Enter.</p>	 <p>Figure 31.</p>
3	<p>The Service UI screen is displayed. Press unit setup button as shown in Figure 32</p>	 <p>Figure 32.</p>

Table 12.

Step	Action	
4	Press the brand mapping button as shown in Figure 33.	 <p>Figure 33.</p>
5	Press the Brand or Flavor icon that is to be remapped.	 <p>Figure 34.</p>
6	The Brand Selection screen opens as shown in Figure 35. and you can select the brand to be mapped to the valve location.	 <p>Figure 35.</p>
7	Repeat Steps 5 & 6 for each location desired.	
8	When all the flavors or brands on the right are mapped, press the left button and repeat Steps 5 and 6 for the left side Or, if the setup will be identical on the LH and RH side, press the copy to other side button and confirm when prompted.	
9	When all the flavors are mapped as desired, press the Save button to save the settings.	

Purging The Syrup Lines

The purge process is performed as part of the “Syrup Line Cleaning & Sanitizing” section on page 25. If a BIB container is replaced, the syrup lines need to be purged and sanitized. To purge the lines, perform the procedure in Table 13.

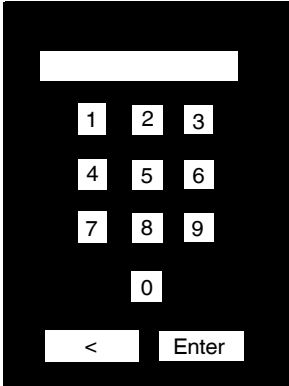
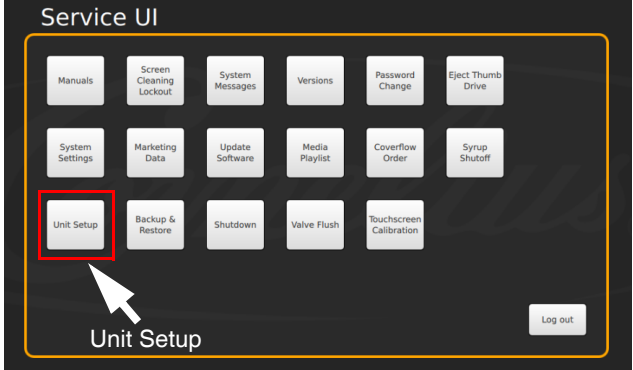
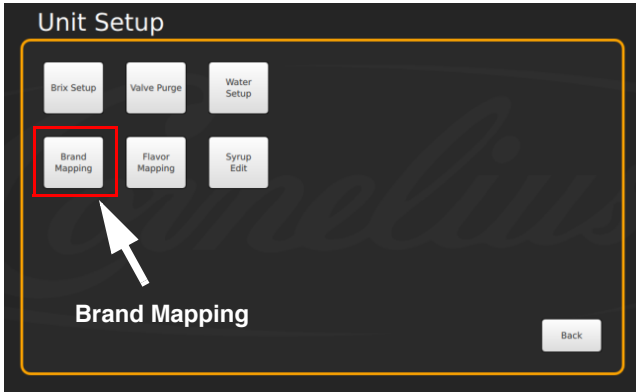
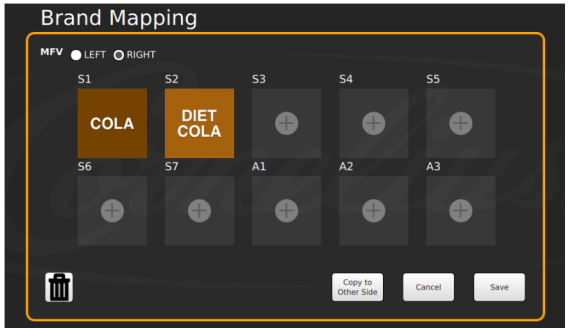
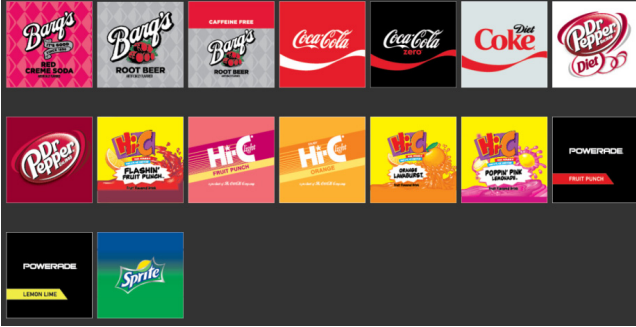
Table 13.

Step	Action	
1	Ensure that the water and CO ₂ are turned on. (initial setup only)	
2	<p>Display the keypad screen by tapping each corner of the video screen starting in the upper right corner (1) and continuing to tap each corner in a counterclockwise direction, in a sequence of 1,2,3 and 4 as shown in Figure 36.</p> <p>NOTE: As each corner is touched, a small confirmation rectangle may momentarily appear to confirm the touch.</p>	 <p style="text-align: center;">Figure 36.</p>
3	Input the proper password for your access level (technician) and press Enter.	 <p style="text-align: center;">Figure 37.</p>
4	The Service UI screen is displayed.	 <p style="text-align: center;">Figure 38.</p>
5	Press the Unit Setup button.	

Table 13.

Step	Action	
6	The Unit Setup screen is displayed. Press the Valve Purge button.	 <p style="text-align: center;">Figure 39</p>
7	<p>The Valve Purge screen is displayed. Select up to 4 syrup and 2 water at a time, per side, to purge.</p> <p>NOTE: 12 minutes default if not turned OFF</p>	 <p style="text-align: center;">Figure 40</p>
8	When the syrup flows and lines are purged, press the same again to turn off upto 4 at once.	
9	Repeat Step 7 until all lines are purged. When doing carbonated water, make sure carbonator is purged.	
10	When all lines are purged, press the Back button to display the Service User Interface screen and select the Log Out button or another selection.	

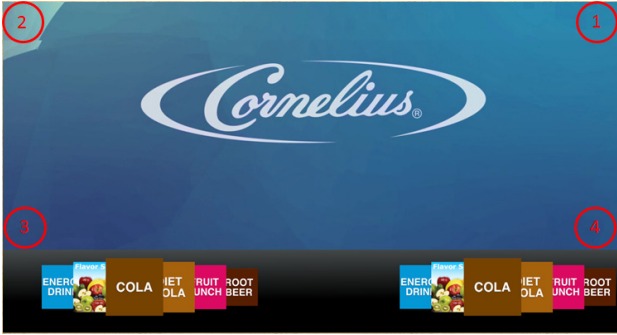
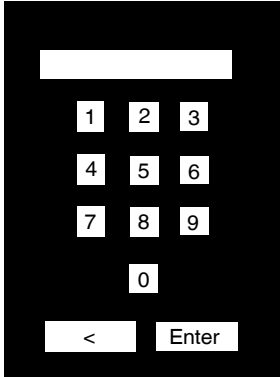
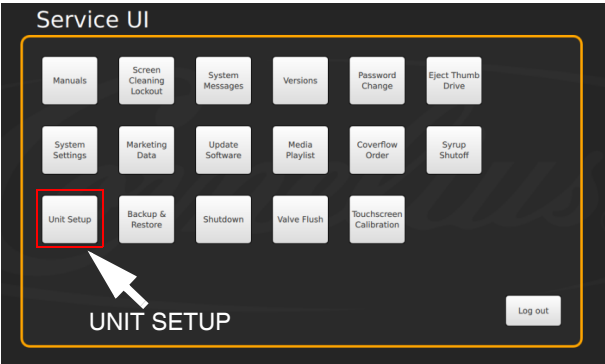
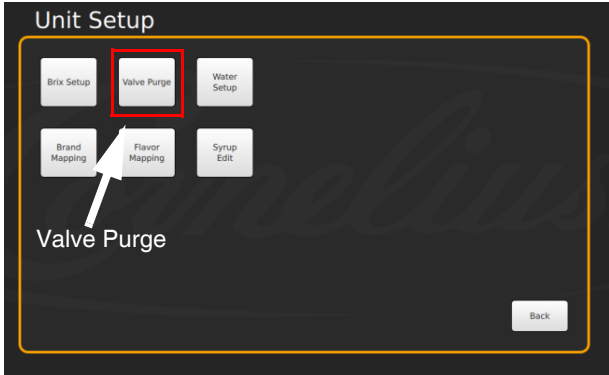
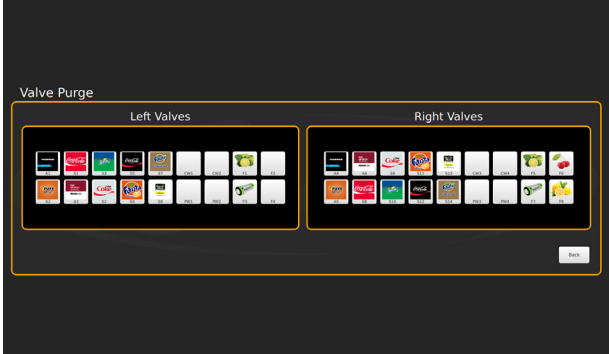

Syrup Line Cleaning & Sanitizing

CAUTION:

Only trained and qualified persons should perform these cleaning and sanitizing procedures. To sanitize the tubing and BIB connectors, perform the procedure in Table 14.

Table 14.

Step	Action	
1	Remove all the quick disconnects from all the BIB containers.	 <p style="text-align: center;">Figure 41.</p>

2	Fill a suitable bucket with a soap solution.	
3	Submerge all disconnects (gas and liquid) in the soap solution and then clean them using a nylon bristle brush. (Do not use a wire brush.) Rinse with clean, potable water.	 <p style="text-align: center;">Figure 42.</p>
4	Using a plastic pail, prepare approximately 5 gallons (18.93 l) of sanitizing solution.	
5	Sanitizing fittings must be attached to each BIB disconnect. If the fittings are not available, the fittings from empty BIB bags can be cut from the bags and used. These fittings open the disconnects so the sanitizing solution can be drawn through the disconnect.	
6	Place all the BIB disconnects with the sanitizing fittings in place into the pail of sanitizing solution. Use the "Purging The Syrup Lines" section on page 24 to purge the lines. Allow the sanitizer to remain in the lines for 15 minutes.	 <p style="text-align: center;">Figure 43.</p>
7	While the lines are soaking, remove the nozzles and syrup diffusers and clean them in a mild soap solution, rinse them with clean water.	
8	Use a mechanical sprayer filled with sanitizing solution to spray the nozzles and diffusers and allow them to air dry.	
9	Reassemble the nozzles and syrup diffusers and replace them on the valves.	
10	Remove the sanitizing fittings from the BIB disconnects and connect the disconnects to the appropriate BIB container.	
11	Use the "Purging The Syrup Lines" section on page 24 to purge the lines. Continue until all the sanitizer has been flushed from the system and only syrup is flowing.	

Adjusting the Water to Syrup Ratio (BRIX)

NOTE: During the BRIXing process, agitate the ice in the bin occasionally to ensure that the cold plate is at the proper operating temperature.

Water and syrup MUST be cold before checking BRIX.

The unit must be BRIXed initially before the unit is put into operation. To BRIX the unit, perform the procedure in Table 15.

Table 15.

Step		Action
1	<p>Display the keypad screen by tapping each corner of the video screen starting in the upper right corner (1) and continuing to tap each corner in a counterclockwise direction, in a sequence of 1,2,3 and 4 as shown in Figure 44.</p> <p>NOTE: As each corner is touched, a small confirmation rectangle may momentarily appear to confirm the touch.</p>	 <p>Figure 44.</p>
2	<p>Input the proper password for your access level (technician) and press Enter.</p>	 <p>Figure 45.</p>
3	<p>Press the Unit Setup button.</p>	 <p>Figure 46.</p>

Table 15.

Step		Action
4	Select the Brix setup screen as shown in Figure 47.	 <p style="text-align: center;">Figure 47.</p>
5	All instructions and volumes below are based on the pour rate of 3 oz/sec	 <p style="text-align: center;">Figure 48.</p>
6	Place a graduated cylinder or brix cup under the valve.	
7	Select the CW1 button and press Pour to dispense 10 oz (295.7ml).	
8	If the flow rate is not correct, adjust the proper valve to the desired flow. Refer to Figure 49 for valve locations.	
9	Turn the flow adjustment valve a 1/4 of a turn at a time and recheck the flow. To increase the flow, turn the knob clockwise.	
10	Test the valve and adjust until a consistent ratio is delivered two consecutive times.	
11	Select PW1 and press Pour to dispense 10 oz (295.7ml.).	
12	Perform Steps 8 through 10 for the PW1 valve.	
13	Select CW3 and Pour to dispense 10 oz (295.7ml.).	
14	Perform Steps 8 through 10 for the CW3 valve.	
15	Select PW3 and press Pour to dispense 10 oz (295.7ml.).	
16	Perform Steps 8 through 10 for the PW3 valve.	
17	Place a graduated cylinder under the valve.	
18	Select S1 and press Pour to dispense 2.0 oz (60 ml.).	
19	If the rate is not correct, perform Steps 8 through 10 for the S1 valve.	
20	Repeat Steps 18 and 19 for S2 through S7 and A1 through A3.	
21	Repeat Steps 18 through 19 for S8 through S14 and A4 through A6.	
22	When the flow rate process is complete, select the Back button to return to the Unit Setup screen.	
23	Press the Back button on the Unit Setup screen to return to the Service UI screen.	
24	Press the Log Out button to return to normal operation.	

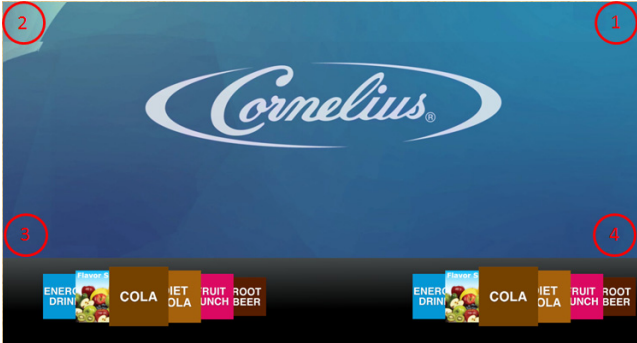
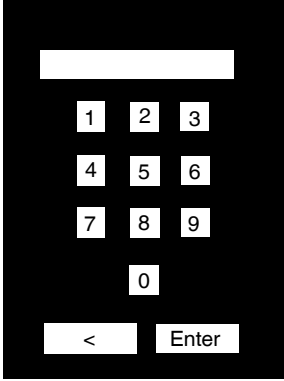
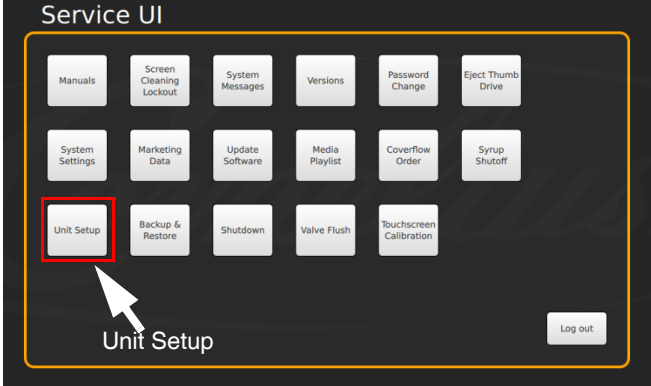
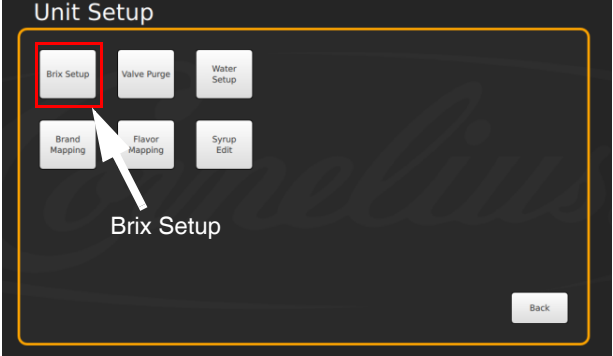
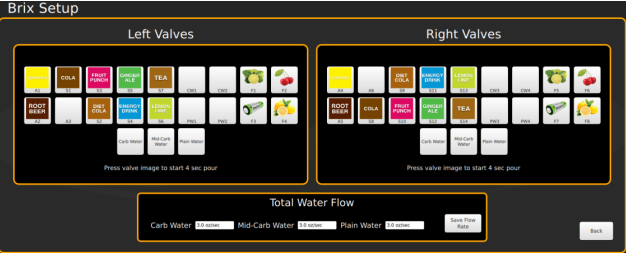
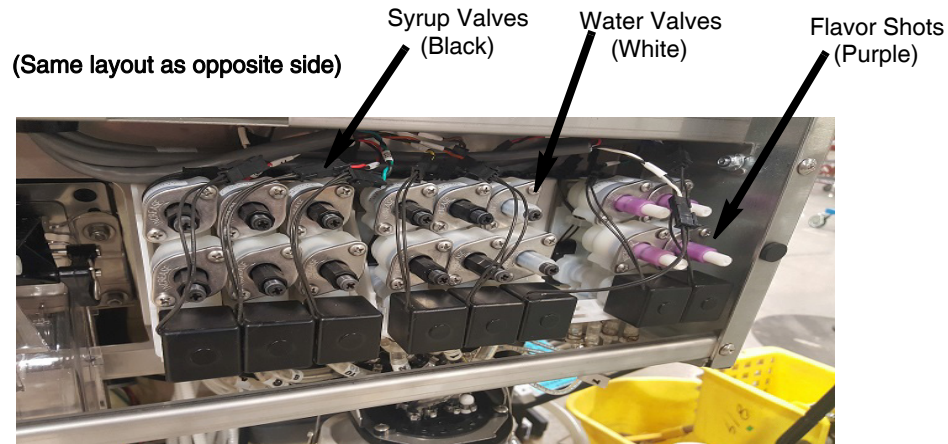

Figure 49.

Cleaning Interior Surfaces

As part of the monthly cleaning and sanitizing the hopper, perform the procedure in Table 16.



CAUTION:

When pouring liquid into the hopper, do not exceed the rate of 1/2 gallon per minute. Pouring liquid into the hopper faster than the recommended rate could result in an overflow situation which may result in personal injury or damage to the equipment.

Table 16.



Step	Action	
1	Remove the agitator assembly by unscrewing the thumbscrew and lifting the agitator assembly out of the hopper.	 <p data-bbox="1036 1514 1149 1541">Figure 50.</p>
2	Using a nylon bristle brush or sponge, clean the interior of the hopper, top cover and agitator assembly with soap solution. Thoroughly rinse the hopper, cover and agitator surfaces with clean potable water.	 <p data-bbox="1036 1902 1149 1929">Figure 51.</p>

Table 16.





Step	Action	
3	<p>Reassemble agitator assembly. Take special care to ensure that the thumbscrew is tight.</p>	 <p style="text-align: center;">Figure 52.</p>
4	<p>Using a mechanical spray bottle filled with sanitizing solution, spray the entire interior and the agitator assembly. Allow them to air dry.</p>	 <p style="text-align: center;">Figure 53.</p>
5	<p>Open the display panel and remove the ice chute cover from the unit.</p>	 <p style="text-align: center;">Figure 54.</p>

Table 16.

Step	Action	
6	With a nylon bristle brush or sponge, clean the inside of the ice chute, gasket, and cover with soap solution and rinse thoroughly to remove all traces of detergent.	 <p data-bbox="1036 783 1149 814">Figure 55.</p>
7	Reassemble the ice chute assembly.	
8	Using a mechanical spray bottle filled with sanitizing solution, spray the inside of the ice chute. Allow it to air dry.	 <p data-bbox="1036 1308 1149 1339">Figure 56.</p>
9	Close the display panel.	

UPDATING SOFTWARE REVISIONS

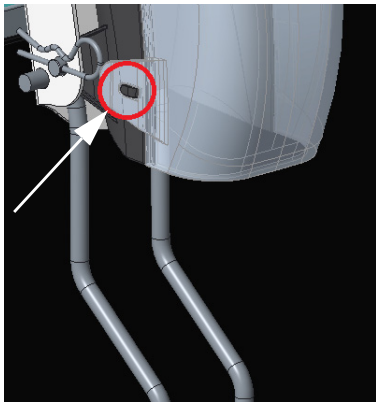
The unit can be updated as new versions of software become available, they may be installed on the unit by performing the procedure in Table 17.

Table 17.

Step	Action	
1	Enter Service mode, as described in “Service Mode” section on page 20.	
2	Open the display panel.	

Table 17.



Step	Action	
3	On the back of the display, unplug the USB connection to the ADA panel and plug in the USB stick as shown in Figure 57 with the software update loaded on it.	 <p data-bbox="1019 783 1138 814">Figure 57.</p>
4	Press the Update Software button.	 <p data-bbox="1024 1205 1138 1236">Figure 58</p>
5	The Update Software screen is displayed. Press the Launch Software Updater button.	 <p data-bbox="1019 1617 1138 1648">Figure 59.</p>

Table 17.

Step	Action	
6	The Software Updater screen is displayed. Press the Update Software button.	 <p style="text-align: center;">Figure 60.</p>
7	The second Update Software screen is displayed.	 <p style="text-align: center;">Figure 61.</p>
8	Select the software version to be installed by selecting from the list on the left side of the screen. If the list on the left side of the screen is empty, press the Scan button. This reads the software updates contained on the USB stick. When the proper version is highlighted, press the Install Software button on the right side of the screen.	
9	When the update is complete, press the Back button to revert to the previous screen, then press the Restart/Refresh button to restart the unit.	
10	Unplug the USB stick from the connector and reinstall the ADA cable.	
11	Close the display panel.	

EDITING THE MEDIA PLAYLIST

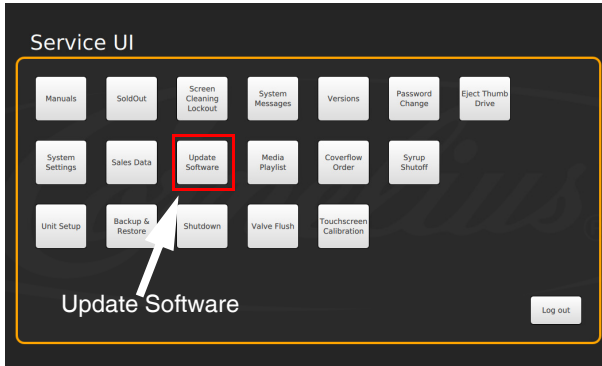
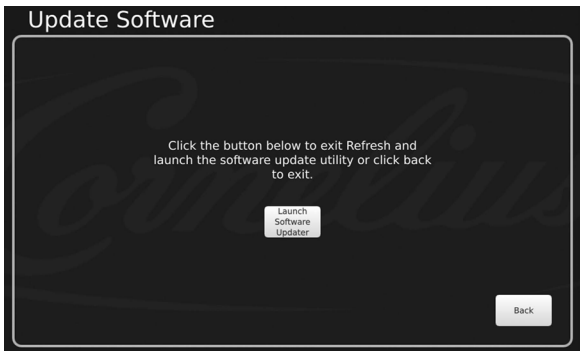
The unit is capable of changing the display video on a preprogrammed schedule. This allows the user to set a specific time and duration for playing a specific media for breakfast, lunch, dinner or any special media required.

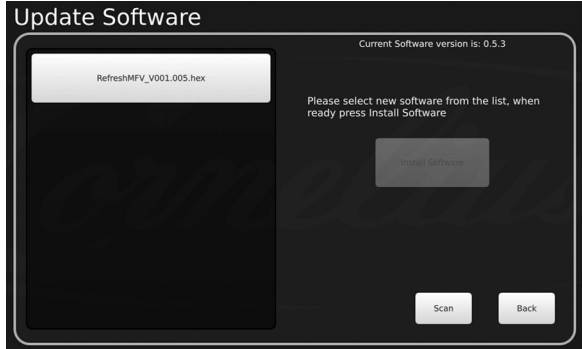
To set the media playlist schedule, perform the procedure in Table 18.

Table 18.



Step	Action	
1	First, enter the Service Screen at either manager or technician level permissions.	
2	Display the keypad screen by tapping each corner of the video screen starting in the upper right corner (1) and continuing to tap each corner in a counterclockwise direction, in a sequence of 1,2,3 and 4 as shown in Figure 62.	 <p data-bbox="1052 674 1170 705">Figure 62.</p>
3	Input the proper password for your access level (technician) and press Enter.	 <p data-bbox="1052 1115 1170 1146">Figure 63.</p>
4	This will take you to the Service UI screen.	 <p data-bbox="1052 1503 1170 1535">Figure 64.</p>
5	This is where you can access the videos (Media Play-list) and sales information (Marketing Data). To start with changing the play-list, select the “Media Play-list” button as shown in Figure 65. This brings you to this screen (only the default play-list appears initially).	 <p data-bbox="1052 1902 1170 1934">Figure 65.</p>

Table 18.

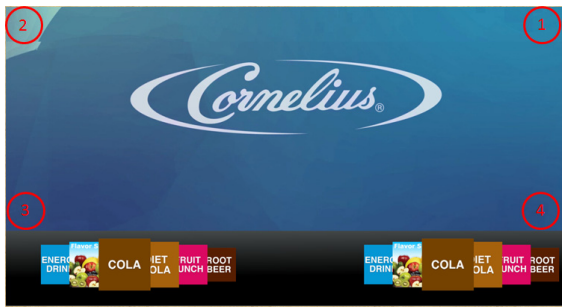
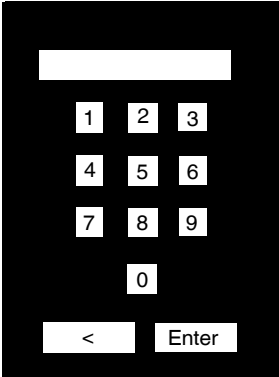

Step	Action	
6	<p>First, to manipulate the play-list and their schedule. A new play-list can be added by selecting the second button on the bottom left (with the + symbol). This will add a new play-list in addition to the default play-list. The times when it starts playing and finishes can be adjusted by dragging the play and stop handles left and right. The corresponding times appear in the bar shown. So, the “breakfast” play-list in Figure 67 plays from 7:30 to 9:00am. The default play-list will fill in the gaps and plays unless any other play-list is set at that time.</p> <p>Now, to modify what’s actually in these play-list (or their names), select the pencil on the RH side of the play-list. The next screen will appear:</p>	 <p>Figure 66.</p>  <p>Figure 67.</p>
7	<p>At the top is the name, click on the white box and a keyboard will appear to allow you to change the name. Below this are two lists of videos. On the RH side is the play-list that you are editing. The videos will play, starting at the top, and repeat, throughout its specified time. To remove a video from the play-list, select it from the list and press the ‘X’ on the right side. To add a video that is on the machine to the play-list, select it from the list on the left and press the arrow in the center. The position of this video can be changed by using the ‘up’ and ‘down’ arrows on the right.</p> <p>Static image option: you can add .jpeg and .png file to the play-list and adjust their duration with the slider on the media play-list menu.</p> <p>To add a video from a USB drive, select the “Add/Del Videos” button in the bottom left. Next screen will pop up:</p>	 <p>Figure 68.</p>

Table 18.

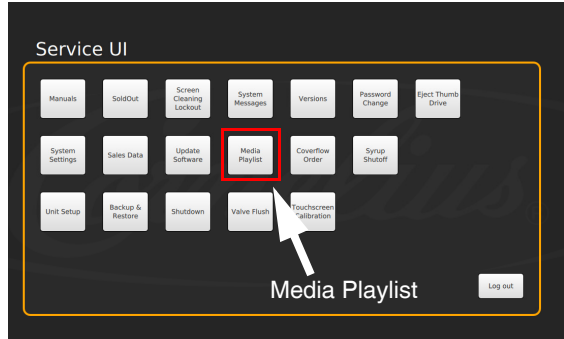
Step	Action	
8	<p>All the videos or images currently on the machine are shown on the right. A USB stick that is connected to any of the (3) available ports will be displayed on the left. Click on the name of the drive and, subsequently, through any folders to find the videos to be added.</p> <p>NOTE: 2GB max video format mp4 (H.264) size:1920 X 880</p>	 <p style="text-align: center;">Figure 69.</p>
9	<p>These videos can be transferred to the machine by selecting them and pressing the arrow button in the center. Any videos that were added are now available to the play-list by pressing the 'Back' button. File can also be copied from the machine to USB drive by selecting the files on the RH side and pressing the left facing arrow.</p> <p>NOTE: If attached files are deleted they will be deleted from the USB drive.</p>	 <p style="text-align: center;">Figure 70.</p>
10	<p>Important Note: Please press save on the Play-list Edit screen and again on the Media Play-list screen when making any changes.</p>	
11	<p>To export sales information, return to the main service UI. Insert a USB drive in an available USB slot on the back of the door. Select "Marketing Data" and again select "Export Data". The data will be exported directly to the USB.</p>	

REPORTING SALES DATA

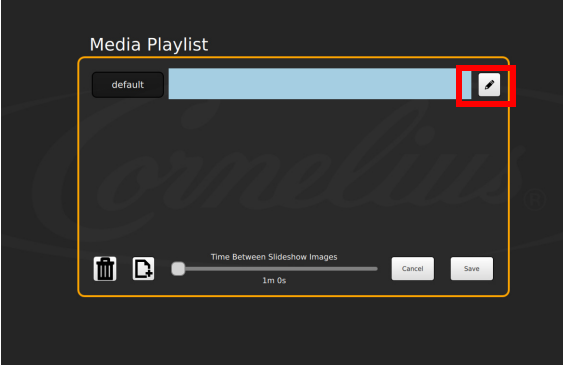
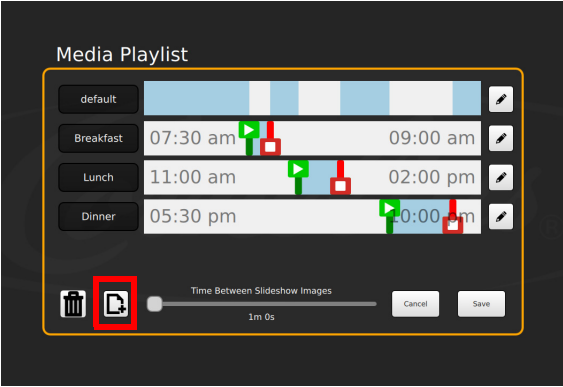
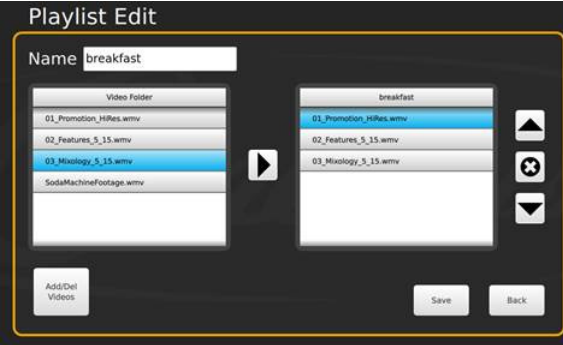
Sales data can be transferred to a USB flash drive for external analysis. To transfer sales data to a USB flash drive, perform the procedure in Table 19.

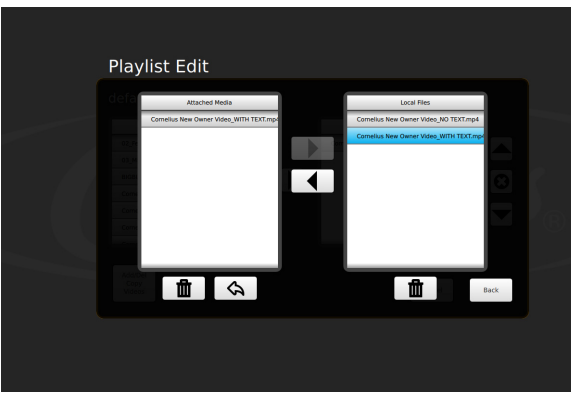
Table 19.

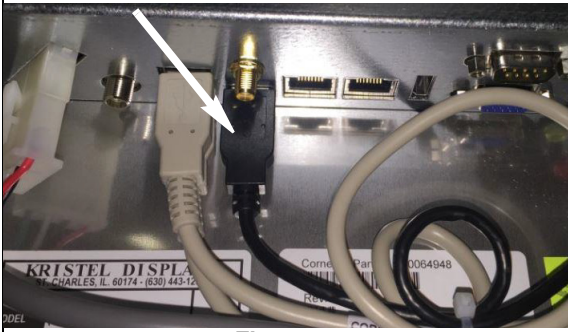

Step	Action	
1	Open the dispenser door.	
2	Unplug the black USB cable from the rear of the door, replace it with a USB flash drive.	<p data-bbox="678 478 906 506">ADA USB Connector</p>  <p data-bbox="889 835 1003 863">Figure 71.</p>
3	Enter Service mode, as described in “Service Mode” section on page 20.	
4	Select Sales Data from the Service UI screen.	 <p data-bbox="889 1283 1003 1310">Figure 72.</p>

Table 19.

Step	Action																																		
5	Select Export Data from the Marketing Data screen,	<div data-bbox="565 296 1135 630"> <p>Media Devices</p> <p>REFRESH</p> <p>Please select Media Device</p> <p>Export Data</p> </div> <p style="text-align: center;">Figure 73</p> <div data-bbox="565 688 1135 1003"> <p>REFRESH</p> <p>Please select Media Device</p> <p>Export Data</p> <p>Exporting data...</p> <p>Back</p> </div> <p style="text-align: center;">Figure 74.</p>																																	
6	Sales data appears as shown in Figure 75	<div data-bbox="565 1073 1135 1388"> <p>Sales Data</p> <table border="1"> <thead> <tr> <th>Syrup Name</th> <th>Drink Oz</th> <th>Count</th> </tr> </thead> <tbody> <tr><td>Coca Cola Classic</td><td>1044.23</td><td>127</td></tr> <tr><td>Diet Coke</td><td>116.80</td><td>29</td></tr> <tr><td>Coke Zero</td><td>21.02</td><td>9</td></tr> <tr><td>Fanta Orange</td><td>24.60</td><td>9</td></tr> <tr><td>Fuze Unsweetened Tea</td><td>11.77</td><td>2</td></tr> <tr><td>Minute Maid Light Lemonade</td><td>21.07</td><td>3</td></tr> <tr><td>Sprite</td><td>159.73</td><td>22</td></tr> <tr><td>Fuze Lemon Tea</td><td>9.00</td><td>2</td></tr> <tr><td>PW - Plain</td><td>111.47</td><td>5</td></tr> <tr><td>Subway Sparking Water</td><td>363.41</td><td>26</td></tr> </tbody> </table> <p>By Syrup By Flavors Chart Export Data Clear Data Back</p> </div> <p style="text-align: center;">Figure 75.</p>	Syrup Name	Drink Oz	Count	Coca Cola Classic	1044.23	127	Diet Coke	116.80	29	Coke Zero	21.02	9	Fanta Orange	24.60	9	Fuze Unsweetened Tea	11.77	2	Minute Maid Light Lemonade	21.07	3	Sprite	159.73	22	Fuze Lemon Tea	9.00	2	PW - Plain	111.47	5	Subway Sparking Water	363.41	26
Syrup Name	Drink Oz	Count																																	
Coca Cola Classic	1044.23	127																																	
Diet Coke	116.80	29																																	
Coke Zero	21.02	9																																	
Fanta Orange	24.60	9																																	
Fuze Unsweetened Tea	11.77	2																																	
Minute Maid Light Lemonade	21.07	3																																	
Sprite	159.73	22																																	
Fuze Lemon Tea	9.00	2																																	
PW - Plain	111.47	5																																	
Subway Sparking Water	363.41	26																																	

Cornelius Inc.
www.cornelius-usa.com