



Viper™ Remote

Remote Condenser

Specification Guide

VIPER™ REMOTE



Features

Remote Condenser

Remote and air-cooled condenser options available

High Capacity

Surge capacity dispensing 10 (16oz) consecutive drinks per barrel with a continuous draw capacity of 75-82 fl.oz per minute

Patented Intelligent Defrost™

Manages product quality and bypasses unnecessary defrost times

Defrost Lock-Out Times

Schedule defrost lockout times to avoid down time during peak demand periods

Sleep Mode

Schedule sleep modes to conserve energy during off hours

QR Code

Quickly access service manuals and easy-to-follow training videos

C3 Technology

Cooling, carbonation, and controls provide unmatched drink profile consistency and minimizes syrup usage

Serviceability

Reduced maintenance and service times with a 0.3% out of the box failure rate

Programmable Flavor Barrels

Individual barrel flexibility and profile settings

ADA Compliant

Stainless push handle valve



MARMON
Foodservice
Technologies



A BERKSHIRE HATHAWAY COMPANY



Viper™ Remote Remote Condenser

Specification Guide

Technical Specifications

Remote Condenser Electrical Requirements	230V +/- 15V, 60Hz, 15A, Single Phase 230V +/- 15V, 50Hz, 20A, Single Phase
Remote Condenser Dimensions	38.25"W x 32.23"D x 27.6"H (971.6mm x 818.6mm x 701mm)
Remote Condenser Operating Temperature	-20°F (-28.9°C) to 120°F (48.9°C)
Remote Condenser Weight	165lbs (74.8kg)
Remote Condenser Shipping Weight	180lbs (81.6kg)
Refrigerant	R404A
Minimum Clearance Requirements	30" (762mm) for temperatures < 90°F (32°C)
Agency Listing	  
Additional Required Items Supplied by Installer	<ol style="list-style-type: none"> 1. Mounting hardware for exterior condenser installation 2. Roofing materials for line set and electrical connection roof penetration 3. Nitrogen to pressurize system during brazing and leak check 4. 15% silver brazing compound 5. R404a/R448a Refrigerant - 16 lbs. for 4 barrel, 14.75 lbs. for 3 barrel. @ 50 ft. line length NOTE: For charging requirements, please see <i>Viper Remote Condenser Installation Instructions, Charging Table on Pages 6 and 7</i> 6. Electrical circuit and connection to remote condenser 7. Watertight conduit to run from remote condenser to Viper 8. Electrical junction box to mount on wall behind Viper 9. 14 AWG stranded wires to run from remote condenser to junction box 10. Solenoid magnets
Unit Compatibility	Viper 3 Barrel, 230V, 50/60Hz Viper 4 Barrel, 230V, 50/60Hz <i>Refer to Viper 3 flavor and Viper 4 flavor for product specification</i>

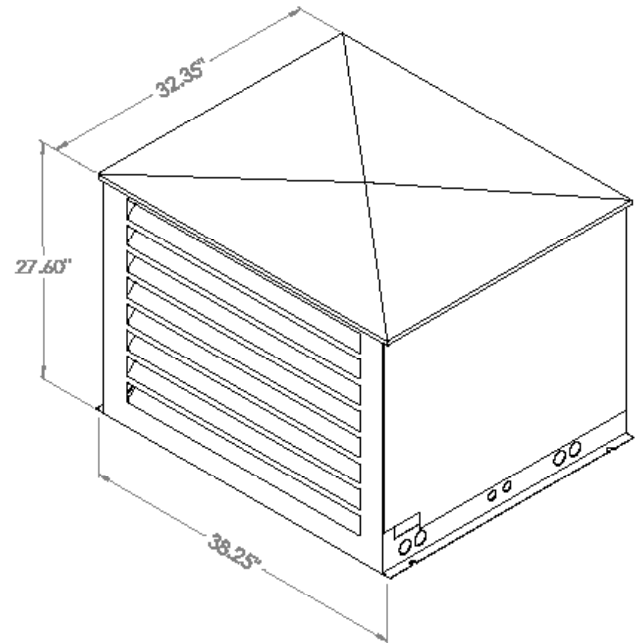

Model Number	Description
620067108	Viper Remote Condenser
<i>Note: A Viper Remote Condenser is required for any Viper Remote Dispenser installation (please contact Cornelius for additional information). Additionally, one of the 2 line set options (marked with**) must also be ordered.</i>	
<i>This equipment is prohibited from use in California in accordance with the California Code of Regulations, title 17, section 95374 and in Colorado, Delaware, Maryland, Massachusetts, New Jersey, New York, Vermont, and Washington and is expected to be prohibited in Virginia by July 1, 2021. This disclosure statement has been reviewed and approved by Marmon Foodservice Technologies, and Marmon Foodservice Technologies attests, under penalty of perjury, that these statements are true and accurate. Consider Viper™ equipment with R448A refrigerant, if available.</i>	

Accessories	Description
620071967	50ft Flexible Line Set (1) 3/8" and (1) 1/2"***
620071969	100ft Flexible Line Set (1) 3/8" (1) 1/2"***
620067479	Buck Boost Transformer (Recommended)
<i>Refer to Installation Manual for required installation materials - A Buck/Boost transformer is recommended for most installations</i> <i>Note: When ordering the Viper Remote Condenser, one of the corresponding dispensers above (marked with*) must be ordered. Additionally, one of the 2 line set options (marked with**) must also be ordered</i>	

To learn more and see **Viper™** in action, visit cornelius.com
 To contact a Cornelius® expert today, visit cornelius.com/contact-us