

FEATURES

Endless Variety - 8 flavours on a barrel for unlimited combinations; single flavours, dual flavoured and swirled drinks

Customization - Create your beverage; Ability to combine and personalize flavors

Supply Chain Flexibility - Use neutral and flavored base to expand variety without risk of expired product and supply chain complexity

Pulsed Dispensing - Electronically controlled flavor dosing to maintain ratio during dual flavor dispensing.

Digital Interface - User friendly touch screen control for simple operation.

Retrofitable - FMFV kit designed to retrofit to your current FSB dispenser and Viper/Viper Elite built from 2012-present

Automation - Electrical actuation removes the need to touch the valves

Carryover Management System - Negligible flavor carryover between drinks

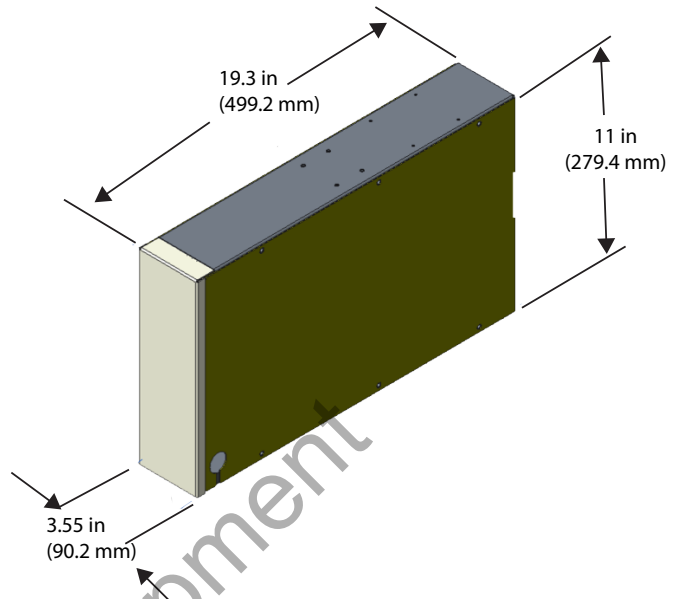
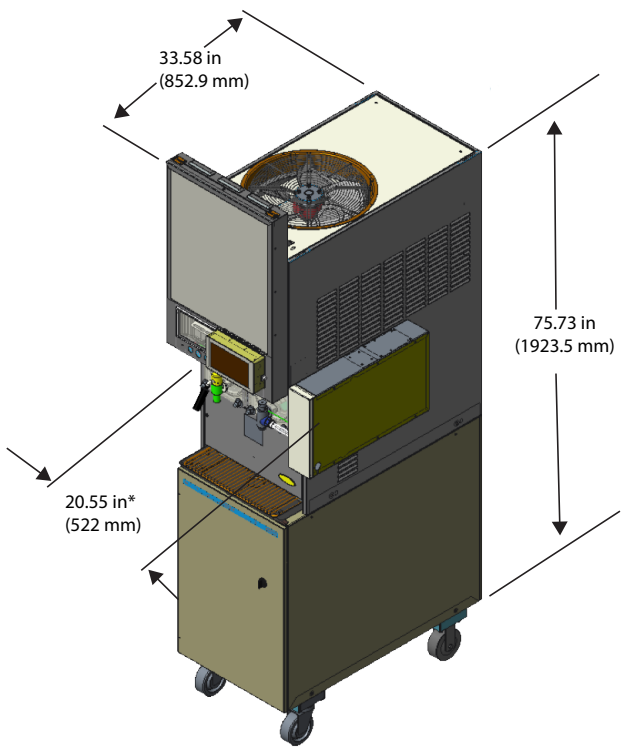

MODELS

PART NUMBER	DESCRIPTION
TBD	TBD

TECHNICAL SPECIFICATIONS

- FLAVOR RATIO 30:1
- FLAVOR FLOW RATE 0.203oz/sec (6ml/sec)
- DRINK FLOW RATE..... 5.9+0.2oz/sec (175+5ml/sec)*
- ELECTRICAL REQUIREMENTS .. 120/230V 50/60 Hz
- UI SIZE..... 7" (122.4mm x 91.44mm)
- DIMENSIONS..... 20.55in (522 mm) W x 33.58 in (852.9mm) D x 75.73 in (1923.5mm) H (with 1 side e-box)
 24.1in (612.2 mm) W x 33.58 in (852.9mm) D x 75.73 in (1923.5mm) H (with 2 side e-boxes)
- SHIPPING WEIGHT 10lbs without pump panel
- OPERATING PRESSURE 40-45 psi (276-310 kPa)
- AGENCY LISTINGS In Process

*Under normal Viper settings. Refer operational manual of Viper for more details

