



## NEW! ENDURO 300 DIGITAL DISPLAY

POST-MIX ICE DRINK DISPENSER



Illuminated Valves with Downlighting

## FEATURES

**Design** - Updated, contemporary look

**High Impact Digital Merchandising** - Attracts customers to your fountain display. Easy to update video messaging via USB or cloud capable

**Dispense All Ice Types** - Can dispense cubed or soft ice (soft ice ready) no need to order any other components to dispense soft ice

**Large Capacity** - 300 lbs Ice Capacity

**Deep Drip Tray** - Helps reduce ice spillage

**Universal Ice Maker Adapter Lid** - Easy to top mount a wide variety of ice makers

**Reliable** - Utilizes proven ED300 cooling and dispensing technology

**Built-in Cold Carbonation** - Delivers consistent high quality beverage

**ADA** - Meets ADA requirements

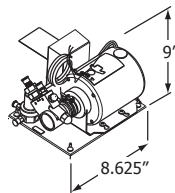
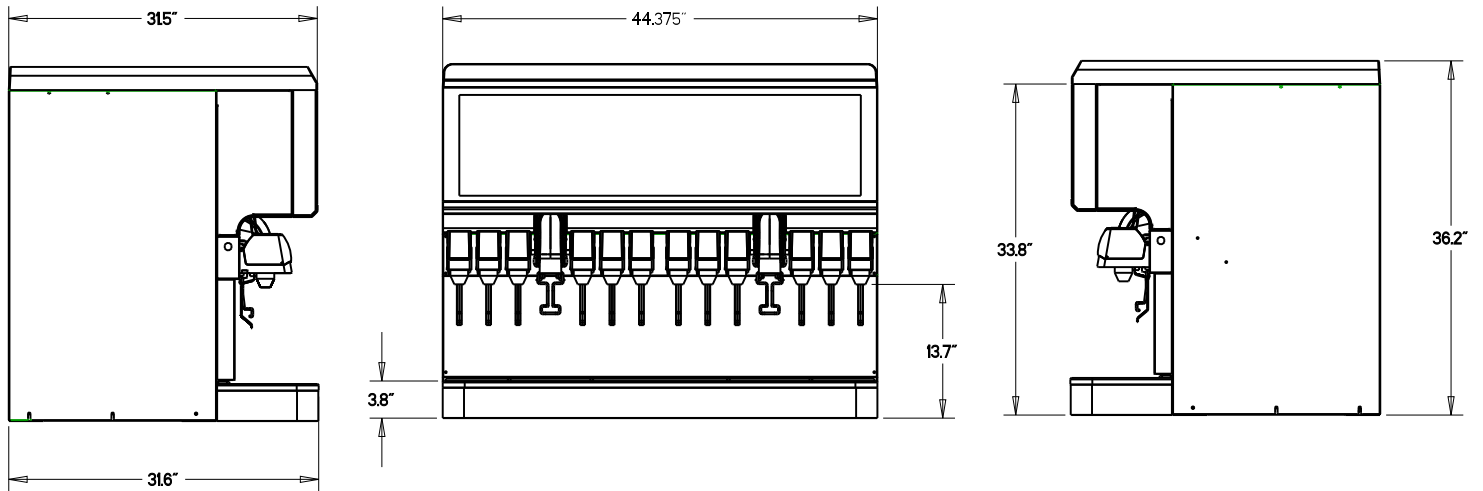

**NOTE: PUMP & MOTOR ASSEMBLY  
MUST BE POSITIONED WITHIN  
8 FEET OF THE DISPENSER**

PART NUMBER	DESCRIPTION
TBD	
TBD	
TBD	

Unit with UFB Sanitary lever meets ADA guidelines on a 34" counter.

## TECHNICAL SPECIFICATIONS

ICE STORAGE CAPACITY . . . . .	300 lb (136 kg)	SCREEN DIMENSIONS . . . . .	40.93"W x 10.23"H
BEVERAGE MANIFOLDING . . . . .	TotalFlex	VIDEO FORMAT . . . . .	MP4 (H.264) 1920x480)
CUP CLEARANCE . . . . .	10" (25.40 cm)	STILL IMAGES . . . . .	jpeg or png (1920x480)
COOLING CAPACITY . . . . .	10-12 oz drinks/min @ 75°F	STANDARD OPTIONS . . . . .	Beverage key switch, Timed ice agitation (order light separately if needed)
DRAIN CONNECTION . . . . .	0.75" PVC (NPT) or 1" ID flexible tubing	SHIPPING WEIGHT . . . . .	485 lb (220kg)
ELECTRICAL RATING . . . . .	115 V / 60 Hz / 8.5 Amps (single outlet)	AGENCY LISTINGS . . . . .	Pending
WATER SUPPLY PRESSURE . . . . .	50-60 psi at pump		
CO <sub>2</sub> . . . . .	90-110 psi bulk CO <sub>2</sub> to pump deck regulator Note: Regulator on the pump and motor deck is set at 75 PSI		

