



---

## SPECIALTY BEVERAGE DISPENSER

### NITROPRO MINI Installation And Operator Manual



**Release Date: November 16, 2018**

**Publication Number: 548000106INS**

**Revision Date: February 4, 2019**

**Revision: 2**

**Model: CNB Mini**

Visit the Cornelius web site at [www.cornelius.com](http://www.cornelius.com) for all your Literature needs.

---

The products, technical information, and instructions contained in this manual are subject to change without notice. These instructions are not intended to cover all details or variations of the equipment, nor to provide for every possible contingency in the installation, operation or maintenance of this equipment. This manual assumes that the person(s) working on the equipment have been trained and are skilled in working with electrical, plumbing, pneumatic, and mechanical equipment. It is assumed that appropriate safety precautions are taken and that all local safety and construction requirements are being met, in addition to the information contained in this manual.

This Product is warranted only as provided in Cornelius' Commercial Warranty applicable to this Product and is subject to all of the restrictions and limitations contained in the Commercial Warranty.

Cornelius will not be responsible for any repair, replacement or other service required by or loss or damage resulting from any of the following occurrences, including but not limited to, (1) other than normal and proper use and normal service conditions with respect to the Product, (2) improper voltage, (3) inadequate wiring, (4) abuse, (5) accident, (6) alteration, (7) misuse, (8) neglect, (9) unauthorized repair or the failure to utilize suitably qualified and trained persons to perform service and/or repair of the Product, (10) improper cleaning, (11) failure to follow installation, operating, cleaning or maintenance instructions, (12) use of "non-authorized" parts (i.e., parts that are not 100% compatible with the Product) which use voids the entire warranty, (13) Product parts in contact with water or the product dispensed which are adversely impacted by changes in liquid scale or chemical composition.

### **Contact Information:**

To inquire about current revisions of this and other documentation or for assistance with any Cornelius product contact:

**[www.cornelius.com](http://www.cornelius.com)**

**800-238-3600**

### **Trademarks and Copyrights:**

This document contains proprietary information and it may not be reproduced in any way without permission from Cornelius.

This document contains the original instructions for the unit described.

CORNELIUS INC  
101 Regency Drive  
Glendale Heights, IL  
Tel: + 1 800-238-3600

Printed in U.S.A.

---

# TABLE OF CONTENTS

<b>Safety Instructions</b> .....	<b>1</b>
Read And Follow All Safety Instructions .....	1
Safety Overview .....	1
Recognition .....	1
Different Types Of Alerts .....	1
Safety Tips .....	1
Qualified Service Personnel .....	2
Safety Precautions .....	2
Shipping And Storage .....	2
Mounting In Or On A Counter .....	2
<b>Specifications</b> .....	<b>3</b>
Unit Dimensions .....	4
Receiving .....	4
Unpacking .....	4
Nameplate Data .....	5
Ice Bank/pull Down .....	5
Applications .....	5
Installation Kit .....	6
<b>Requirements</b> .....	<b>7</b>
Counter Location .....	7
Minimum Airflow Clearance .....	7
Connecting The Water Supply .....	8
Plumbing And Water Supply Requirements .....	8
Electrical Requirements .....	9
<b>Filling The Ice Bath</b> .....	<b>10</b>
<b>Priming/flushing Water System</b> .....	<b>12</b>
<b>Ratio Setting Procedure</b> .....	<b>13</b>
Supplies .....	13
Checking/adjusting The Ratio Setting .....	13
Operating The Controls – Dip Switch Settings: .....	13
Operating The Controls - Micro Adjustment Buttons .....	14
Using The Buttons .....	14
<b>Tds Measurement Guide</b> .....	<b>15</b>
General Guidelines For Targeting Desired Tds/ratio .....	15
Option 1: Using A Tds Meter .....	16
Additional Supplies .....	16
Option 2: Using A Brix Refractometer .....	16
Additional Supplies .....	16
Option 3: Manually Checking Volume Ratio .....	17
Additional Supplies .....	17
<b>Cleaning And Sanitizing</b> .....	<b>18</b>
Clean Splash Zones And Dispense Nozzles .....	18
Weekly .....	18
Sanitizer Product .....	18

---

Cleaner Product .....	18
<b>Changing Coffee Types</b> .....	<b>27</b>
Unit Foam Head Height Adjustment .....	27
<b>System Electrical Diagram</b> .....	<b>30</b>
<b>System Plumbing Schematic</b> .....	<b>31</b>

# SAFETY INSTRUCTIONS

## READ AND FOLLOW ALL SAFETY INSTRUCTIONS

### Safety Overview

- Read and follow **ALL SAFETY INSTRUCTIONS** in this manual and any warning/caution labels on the unit (decals, labels or laminated cards).
- Read and understand ALL applicable OSHA (Occupational Safety and Health Administration) safety regulations before operating this unit.

### Recognition

<i>Recognize Safety Alerts</i>
 <p><i>This is the safety alert symbol. When you see it in this manual or on the unit, be alert to the potential of personal injury or damage to the unit.</i></p>

### Different Types of Alerts

#### **DANGER:**

Indicates an immediate hazardous situation which if not avoided **WILL** result in serious injury, death or equipment damage.

#### **WARNING:**

Indicates a potentially hazardous situation which, if not avoided, **COULD** result in serious injury, death, or equipment damage.

#### **CAUTION:**

Indicates a potentially hazardous situation which, if not avoided, **MAY** result in minor or moderate injury or equipment damage.

### SAFETY TIPS

- Carefully read and follow all safety messages in this manual and safety signs on the unit.
- Keep safety signs in good condition and replace missing or damaged items.
- Learn how to operate the unit and how to use the controls properly.
- **Do not** let anyone operate the unit without proper training. This appliance is **not** intended for use by very young children or infirm persons without supervision. Young children should be supervised to ensure that they do not play with the appliance.
- Keep your unit in proper working condition and do not allow unauthorized modifications to the unit.

**NOTE: The dispenser is not designed for a wash-down environment and MUST NOT be placed in an area where a water jet could be used.**

## QUALIFIED SERVICE PERSONNEL

### **⚠ WARNING:**

Only trained and certified electrical, plumbing and refrigeration technicians should service this unit.

**ALL WIRING AND PLUMBING MUST CONFORM TO NATIONAL AND LOCAL CODES. FAILURE TO COMPLY COULD RESULT IN SERIOUS INJURY, DEATH OR EQUIPMENT DAMAGE.**

**IF THE SUPPLY CORD IS DAMAGED, IT MUST BE REPLACED BY THE MANUFACTURER, ITS SERVICE AGENT OR SIMILARLY QUALIFIED PERSONS IN ORDER TO AVOID A HAZARD.**

## SAFETY PRECAUTIONS

This unit has been specifically designed to provide protection against personal injury. To ensure continued protection observe the following:

### **⚠ WARNING:**

Disconnect power to the unit before servicing following all lock out/tag out procedures established by the user. Verify all of the power is off to the unit before any work is performed.

**FAILURE TO DISCONNECT THE POWER COULD RESULT IN SERIOUS INJURY, DEATH OR EQUIPMENT DAMAGE.**

### **⚠ CAUTION:**

Always be sure to keep area around the unit clean and free of clutter. Failure to keep this area clean may result in injury or equipment damage.

**DO NOT STORE EXPLOSIVE SUBSTANCES SUCH AS AEROSOL CANS WITH A FLAMMABLE PROPELLANT IN THIS APPLIANCE.**

**CHILDREN SHALL NOT PLAY WITH THE APPLIANCE.**

**CLEANING AND USER MAINTENANCE SHALL NOT BE MADE BY CHILDREN WITHOUT SUPERVISION.**

## SHIPPING AND STORAGE

### **⚠ CAUTION:**

Before shipping, storing, or relocating the unit, the unit must be sanitized and all sanitizing solution must be drained from the system. A freezing ambient environment will cause residual sanitizing solution or water remaining inside the unit to freeze resulting in damage to internal components.

## MOUNTING IN OR ON A COUNTER

### **⚠ WARNING:**

When installing the unit in or on a counter top, the counter must be able to support a weight in excess of 185 lbs. (83.9 kg.) to insure adequate support for the unit.

**FAILURE TO COMPLY COULD RESULT IN SERIOUS INJURY, DEATH OR EQUIPMENT DAMAGE.**

**THE APPLIANCE HAS TO BE PLACED IN A HORIZONTAL POSITION**

# SPECIFICATIONS

**Table 1**

Line Voltage - V		115	230
Frequency - Hz		60	50
Phase		1	1
Max Current - A		5	2
Operating Ambient temperature - °F (°C)		50 - 90 (10 - 32)	
Water Inlet Pressure - psi (Kpa)		35 - 90 (206.8 - 620.5)	
Water Inlet Temperature - °F (°C)		40 - 90 (4 - 32)	
Water Inlet Size - Inches (mm)		3/8" (95) SAE Male flare fitting on dispenser	
Equipment Weight - Lbs (Kgs)	Dry	120 (54.4)	
	Operating	185 (83.9)	
Ice Bank Weight - Lbs (Kgs)		6 - 8 (2.7 - 3.6)	
Clearance Requirement	Top - Inches (mm)	12 (348)	
	Sides - Inches (mm)	4 (101.6)	
	Back - Inches (mm)	4 (101.6)	
Unit Dimensions	Height - Inches (mm)	34.05 (865), 30.05 (763) Without legs	
	Width - Inches (mm)	10.44 (265)	
	Depth - Inches (mm)	24.47 (621.5), 25.91 (658) at handles	

## UNIT DIMENSIONS

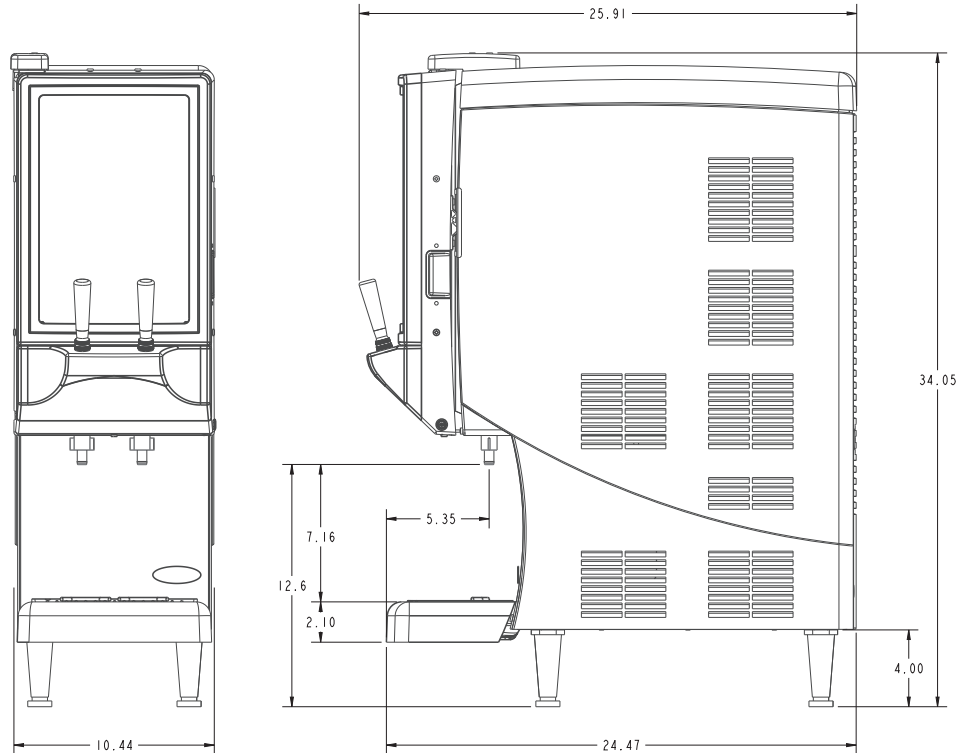

Figure 1

## RECEIVING

Each unit is completely tested and inspected before shipment. At the time of shipment, the carrier accepts the unit and any claim for damage must be made with the carrier.

Upon receiving the unit(s) from the carrier, inspect the carton for visible damage. If damage exists, have the carrier make a note on the bill of lading and file a claim with the carrier.

## UNPACKING

- Remove staples securing carton to pallet.
- Lift carton up and off of unit.
- Remove inserts and shipping bag.
- Open upper cabinet door and remove installation kit.
- Remove bolts securing unit to pallet.
- Lift unit off of pallet.
- Attach 4" length legs to the unit.

**NOTE: Do not lay the unit on it's side or back. This may cause vital oils to drain from the compressor resulting in damage during start-up and consequently voiding the warranty.**



## NAMEPLATE DATA

**Table 2**

Models	VAC	Amps	Ph	Hz	Refrigerant			Test Pressure psi (Kpa) (bar)	
					Oz	Grams	Type	High side	Low side
CNB Mini	115	5	1	60	5.64	160	R-134a	315 (2171.9) / 21.7	140 (965.3) (9.7)
CNB Mini	230	2	1	50	5.64	160	R-134a	315 (2171.9) / 21.7	140 (965.3) (9.7)

## ICE BANK/PULL DOWN

Weight 6-8 lbs. (2.7 - 3.6 kg.). Pull Down: 3 hours at 75°F (24°C)

## APPLICATIONS

This appliance is intended to be used in applications such as the following:

- Staff kitchen areas in shops, offices and other working environments.
- Farm houses and by clients in hotels, motels and other residential type environments.
- Bed and breakfast type environments.
- Catering and similar non-retail applications.

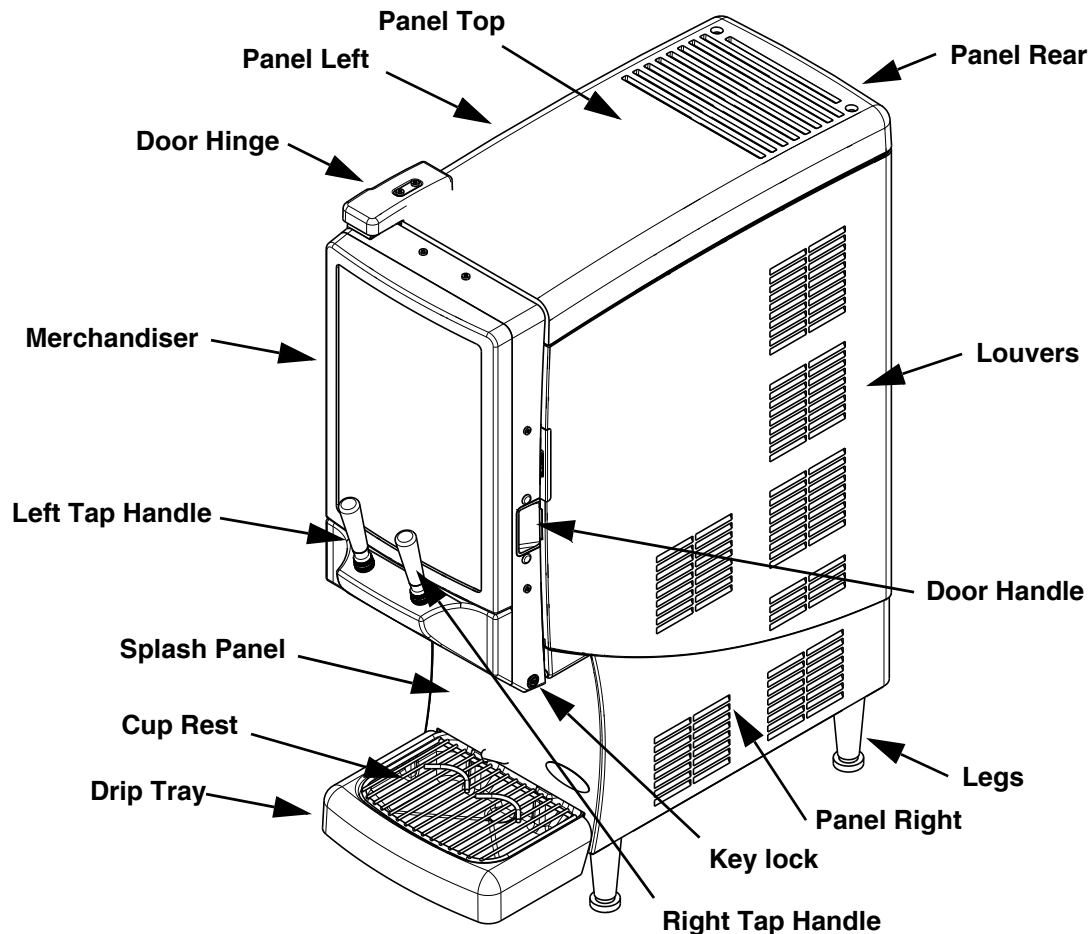
**Figure 2**













**NOTE: Left Tap Handle - Dispenses Still Coffee.  
Right Tap Handle - Dispenses Nitro Coffee.**

## INSTALLATION KIT

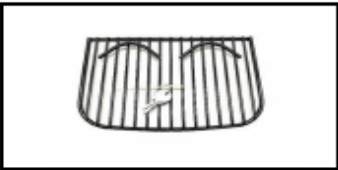
This unit comes with the following components to complete the installation setup.

- Manual
- Legs (4)
- Tube assembly
- BIB adapter
- Drip tray
- Cup rest
- Keys
- Power cord
- 3/8 FFL x 3/8 barbed elbow
- 3/8 Flare gasket

## NitroPro Mini Accessories List

Water Connection	 <p>77040900 - 3/8" Barb Fitting - 1 pc</p>	 <p>40897 - 3/8" Flare Gasket - 1 pc</p>	 <p>309852000 - #17.0 Detiker Clamp - 3 pcs</p>
	 <p>49034 - 3/8" ID Tubing - 6 FT</p>		
Install	 <p>37958 - 4" Leveling Legs - 4 pc</p>	 <p>620049855 - Drip Tray Black - 1 pc</p>	 <p>620708562 - Cup Rest and Key - 1 pc</p>
	 <p>620069835 - BIB Door Cover - 1 pc</p>		
Connectors	 <p>620049959-001 - Power Cord - 1 pc</p>	 <p>620067410 - BIB Hose Assembly - 1 pc</p>	
Cleaning	 <p>620068460 - Cleaning Adapter - 1 pc</p>		
Manuals	 <p>548000106INS - Installation Manual - 1 pc</p>		

# REQUIREMENTS

## COUNTER LOCATION

Select a location in a well ventilated area, close to a grounded electrical outlet. If possible do not place the unit close to hot and/or steaming machines.

## MINIMUM AIRFLOW CLEARANCE

The minimum airflow clearance is: 4" (10.16 cm) in back, 12" (30.48 cm) on top, 4" (10.16) at sides and open to the front.

### **IMPORTANT:**

Condenser air is drawn in from the bottom of the rear panel and discharged out the top of the rear panel & side panels. Failure to maintain clearance space will reduce capacity of the unit and cause premature compressor failure.

The Dispenser needs to be placed using 4" legs that are included.

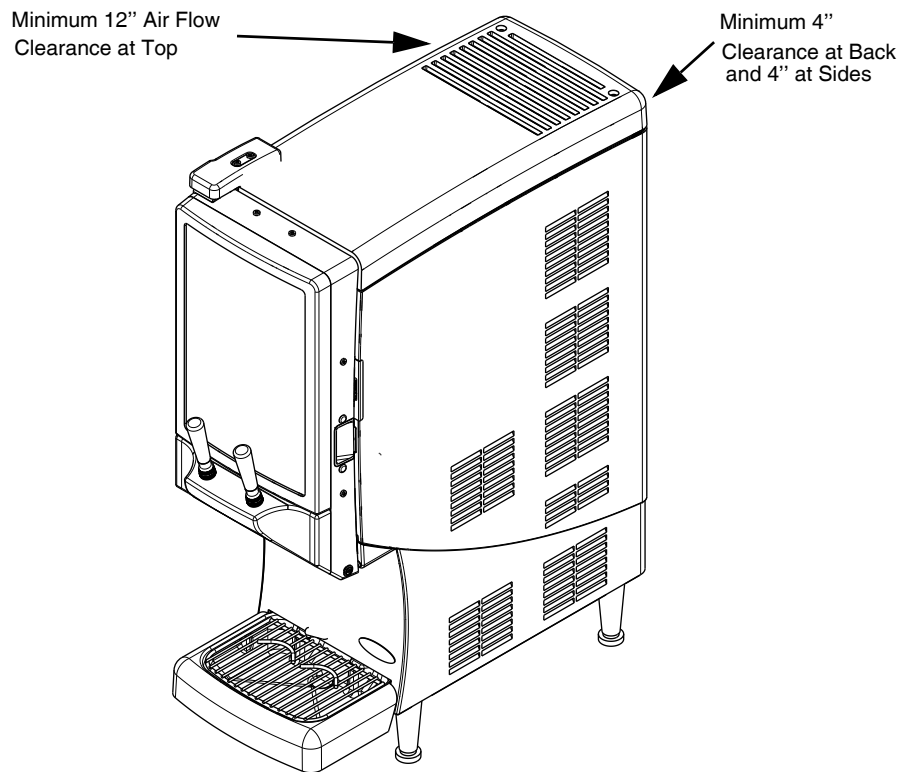

Figure 3

## CONNECTING THE WATER SUPPLY

CNB MINI Dispenser is designed to dispense cold brew nitro coffee. It is very important that the incoming water line be dedicated for use by the dispenser only and does not have other machines connected which could cause a water surge, (i.e., a dishwasher, coffee maker, etc.).

### **⚠ IMPORTANT:**

The water supply should be consistent with proper water quality standards (neutral pH of 7.0 to 8.0), and should not be connected to a water softener. It is the installer's responsibility to ensure that all water connections to the dispenser are sized, installed with adequate backflow protection and maintained to comply with Federal, State, and Local Laws.

## PLUMBING AND WATER SUPPLY REQUIREMENTS

This dispenser must be connected to a **COLD WATER** system with operating pressure between 35 psi (241.3 kPa) (2.4 bar) minimum (dynamic) and 90 psi (620.5 kPa) (6.2 bar) maximum (static). This water source must be capable of producing a minimum flow rate of 3 fluid ounces (88.7 ml) per second. A shut off valve should be installed in the line before the dispenser. Install a regulator in the line when pressure is greater than 90 psi (620.5 kPa) to reduce it to 80 psi (551.6 kPa) (5.5 bar) (dynamic). The regulator is also necessary if the water source has pressure fluctuations.

### **⚠ WARNING:**

This equipment must be installed to comply with the International Plumbing Code of the International Code Council and the Food Code Manual of the Food and Drug Administration (FDA). For models installed outside the U.S.A., you must comply with the applicable Plumbing/Sanitation Code for your area.

**Failure to comply could result in serious injury, death or damage to the equipment.**

1. Install the flared gasket P/N 40897 into the 3/8" swivel nut P/N 77040900. **Figure (4a)**
2. Secure the swivel nut onto the water inlet located at the rear of the dispenser. Secure the flexible supply tubing to the 3/8" barbed end with the supplied clamps. **Figure (4b)**



Figure (4a)

Water Inlet  
with Supply Tubing  
Connected



Figure (4b)

Figure 4

## ELECTRICAL REQUIREMENTS

### **CAUTION:**

Only trained and certified electrical technicians should replace the power cord or the unit should be returned to an Authorized Service Center for power cord replacement.” The replacement cord must meet all requirements of the original equipment manufacturer.

### **WARNING:**

Indicates a potentially hazardous situation which, if not avoided, **COULD** result in serious injury, death, or equipment damage.

1. A minimum of 15 amps electrical service is needed for 120VAC power supply. A minimum of 10 amps electrical service is needed for 230VAC power supply.
2. 6 ft. long (1.83 m) power cord with 3-prong plug is included with the dispenser. Export models are shipped with a European plug.

**NOTE: When the power is supplied to the unit, the air compressor comes on and runs for 10-15 seconds initially.**

## FILLING THE ICE BATH

The ice bath holds approximately 1.62 gallons (6.13 liters) of water. The fill tube is located behind the front splash panel and capped with a red 0.5" plug.

1. Remove the splash panel.



Figure 5

2. Remove the 0.5" plug and attached the tube to the **LEFT** nozzle.

**NOTE: Do not connect to the right nozzle as it will cause the gas to run continuously.**



Figure 6

3. Ensure that the coffee BIB is disconnected inside the cabinet. With the tube attached to the left nozzle, close the door, replace the drip tray and pull the Left Tap Handle until the tank has filled and water trickles from the over flow.

**NOTE: If the BIB is not disconnected from the cabinet, the ice bank will fill with product and will not work.**

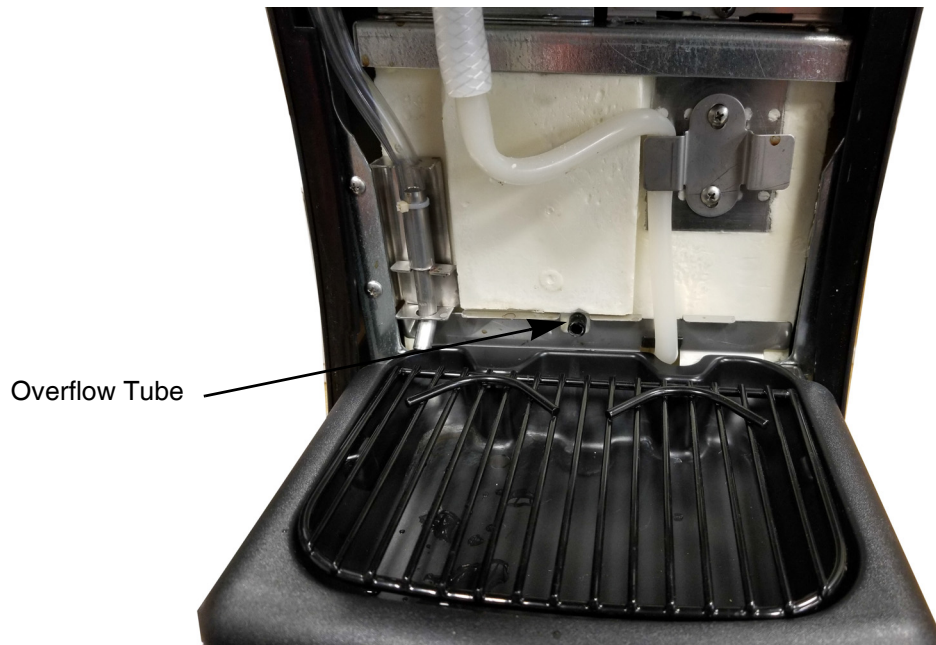

Figure 7

4. Once the ice bath is full, store the fill tube vertically, back in its original location, with the 0.5" cap attached. The fill tube can now be used as a "sight glass" to monitor the water level in the ice bath.



Figure 8



## PRIMING/FLUSHING WATER SYSTEM

Close the door and pull the Tap Handles for a few seconds. Repeat until a steady flow of water is observed from all dispense valves.

**NOTE:** Some splashing may occur during this purge cycle.

**NOTE:** Dispense motor switch should be in “ON position”.

**NOTE:** When the power is supplied to the unit, the air compressor comes on and runs for 10-15 seconds initially.

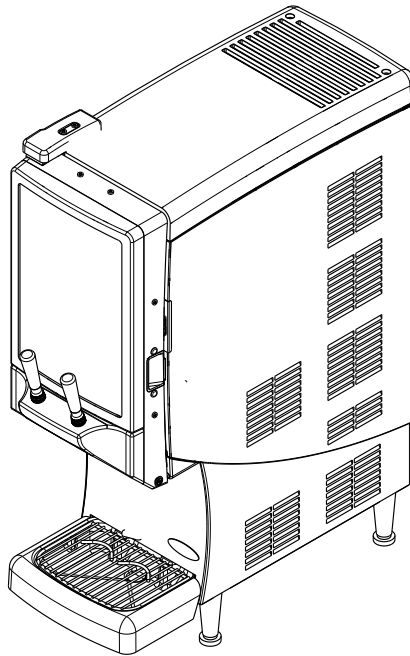

Figure 9



# RATIO SETTING PROCEDURE

**NOTE:** If concentrate is not properly thawed, it will adversely affect the amount of concentrate dispensed. Thawed product should be between 35°F/1.6°C to 40°F/4.4°C. Thawed product should have no ice particles remaining in the BIB.

## SUPPLIES

- 1 - Small 12 oz. cup (354.8 ml)
- 1 - Large 21 oz. cup (621.1 ml)
- 1 - Straw
- 1 - Thermometer
- 1 - Phillips head screw driver
- Paper Towels

## CHECKING/ADJUSTING THE RATIO SETTING

### Operating the Controls – Dip Switch Settings:

1. The unit is setup to have ‘pre-configured’ ratios at options of 3:1, 4:1, 5:1 and 7:1. These ratios are chosen by setting the dip-switch to the corresponding number in the table below.
2. The dip-switches are accessed by removing the splash panel (see page 10 for removing splash panel in the ‘Filling the Ice Bath’ steps).
3. To set the dip switch position, use a small flat head screw driver to set the desired switch flipped ‘UP’ with all other switches ‘DOWN’.

**NOTE:** If multiple switches are up at the same time, it will go to a factory default setting and not target the desired ratio.

**NOTE:** The unit should come pre-configured at a factory setting of ‘5:1’ at dip-switch ‘position 3’

See photo below for an example of the dip-switch at ‘position 3’ for a target ‘5:1’ setting.

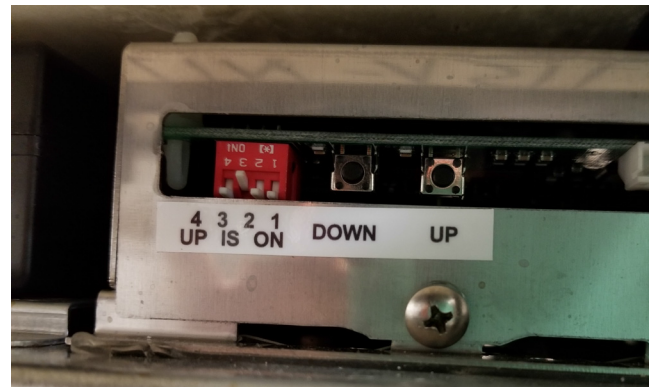

Figure 10

Table 3

Concentrate Target Ratio	Dip Switch Position
3:1	1
4:1	2
5:1	3
7:1	4

## Operating the Controls - Micro Adjustment Buttons

Directly to the right of the dip-switches are two micro-switch buttons marked 'DOWN' and 'UP'. These buttons adjust the motor speed down and up to adjust the ratio further. While the machine comes preset to 5:1, the default settings will have some variance due to coffee products used, water supply variance, and unit tolerances. These buttons can be used to calibrate the machine accurately to the desired ratio once installed.

### Using the Buttons

1. Pressing on the 'UP' micro-switch button will adjust the motor speed up, resulting in a lower ratio (i.e. higher TDS/Brix)
2. Pressing on the 'DOWN' micro-switch button will adjust the motor speed down, resulting in higher ratio (i.e. lower TDS/Brix).
3. Typically, pressing the button once will adjust the average TDS by a value of .02 to .08. The amount of change is dependent on the coffee product, and assumed a thoroughly mixed (homogenous) coffee concentrate.
4. Example: Upon installation of the machine, a TDS of 1.45 is measured at the dispense point. If the target TDS for the theoretical product is actually 1.6. The 'UP' button should be pressed to increase the TDS. The button may need to be pressed several times to reach the desired result.

# TDS MEASUREMENT GUIDE

## GENERAL GUIDELINES FOR TARGETING DESIRED TDS/RATIO

1. Set the dip-switch to the desired ratio target setting.
2. Shake the bag, prior to installing.
3. Dispense approximately 16oz of drink and discard. This is done to purge out any water or coffee from previous settings.
4. Draw an 8oz drink into a clean dry cup, and measure the temperature to confirm the drink is between 35 to 45°F.

**NOTE: Drink temperature must be maintained to properly set the ratio of the unit.**

5. Stir the sample thoroughly, and measure the TDS of the drink (Use any of the 3 options described below to measure the TDS / Ratio).
6. If the TDS matches the desired range of the product, no further adjustments are necessary. If the TDS is above/below required the desired setting, use the 'UP' or 'DOWN' Micro buttons as necessary to target the desired value.

**NOTE: A 16oz drink should be dispensed to purge the previous setting before measuring again.**

**NOTE: It is recommended to make adjustments in 1-2 button pushes at a time to avoid 'overshooting' the target value.**

7. Once the desired value is reached, the setup is complete and should be stable with standard maintenance of the equipment. The splash panel can be placed back on and no further work is needed.

**NOTE: This value will not reset from cleaning mode or power loss.**

**NOTE: If a coffee concentrate flavor, manufacturer or ratio type is changed, then this process should be repeated. This process is not needed for changing BIBs of the same type of coffee concentrate.**

There are 3 different methods that can be used to check/calibrate the ratio setting of the equipment.

1. Using a TDS Meter
2. Using a Brix Meter/Refractometer
3. Manually Checking Volume Ratio

For all 3 methods, first access the ratio control board by removing the splash panel (see Page 10 for removing splash panel in the 'Filling the Ice Bath' steps).

## OPTION 1: USING A TDS METER

### Additional Supplies

- Coffee TDS meter

A TDS meter measures the Total Dissolved Solids in a drink. In the case of coffee, it measures the level of extraction and can be used to ensure the right ratio of water to coffee concentrate is achieved. If the TDS target is known, a TDS meter will allow for a very simple process to measure and ensure proper calibration of the equipment.

1. Follow instructions for the TDS meter to ensure proper calibration and 'zero' set prior to starting this process.
2. Follow steps 1-5 in the '**General Guidelines for Targeting Desired TDS/Ratio**' section (refer to page 15).
3. Using a straw, transfer a small sample of the finished drink to a clean cup for temperature compensation.
4. Let the small sample warm to room temperature before transferring to the TDS meter lens (refer to operating instructions specific to your coffee TDS meter for exact process).
5. Check TDS value... etc.
6. Adjust the unit settings and purge as noted in steps 6-7 in the '**General Guidelines for Targeting Desired TDS/Ratio**' section (refer to page 15).

**NOTE: This method measures TDS, so the 'UP' button will adjust TDS up, and the 'DOWN' button will adjust TDS down.**

## OPTION 2: USING A BRIX REFRACTOMETER

### Additional Supplies

- Refractometer

A brix refractometer is used to measure the sugar content in aqueous solutions. This method may not apply to all coffee concentrates, but many concentrates have natural sugars that allow a brix refractometer to be used. In order to use this method, the target brix value must be known for the coffee concentrate.

1. Follow instructions for the brix refractometer to ensure proper calibration and 'zero' set prior to starting this process.
2. Follow steps 1-5 in the '**General Guidelines for Targeting Desired TDS/Ratio**' section. (refer to page 15).
3. Using a straw, transfer a small sample of the finished drink to the brix refractometer meter lens (refer to operating instructions specific to your brix refractometer for exact process).
4. Check the brix value on the meter.
5. Adjust the unit settings and purge as noted in steps 6-7 in the '**General Guidelines for Targeting Desired TDS/Ratio**' section (refer page 15).

**NOTE: Since this method measures Brix, so the 'UP' button will adjust Brix up, and the 'DOWN' button will adjust Brix down.**

## OPTION 3: MANUALLY CHECKING VOLUME RATIO

### Additional Supplies

- Weighing scale

Following steps explain measuring the water to coffee concentrate ratio using weight.

**NOTE: Weight can be substituted by volume if weighing scale is not handy.**

1. Follow steps 1-5 in the '**General Guidelines for Targeting Desired TDS/Ratio**' section (refer to page 15).
2. Pull Left & Right Tap Handles for 10 seconds one after other to make sure coffee is dispensing.
3. Set 10 seconds timer.
4. Pull Left Tap Handle for 10 seconds to dispense the coffee and weigh the product dispensed.
5. Divide #4 by the total parts to get target coffee concentrate dispense weight.
6.
  - a) If the total dispense is 300 grams and desired ratio is 5:1 divide by 6 to get 50 grams concentrate target for a 10 second pour.
  - b) If the total dispense is 300 grams and desired ratio is 4:1 divide by 5 to get 60 grams concentrate target for a 10 second pour.
  - c) If the total dispense is 300 grams and desired ratio is 3:1 divide by 4 to get 75 grams concentrate target for a 10 second pour.
7. Turn off water to machine.
8. Pull Left Tap Handle for 5 seconds or until coffee is darker and only concentrate is dispensed.
9. Set 10 seconds timer and dispense concentrate by pulling the Left Tap Handle.
10.
  - a) If weight is greater than #6 target use 'DOWN' button on controller to slow the concentrate motor down.
  - b) If weight is less than #6 target use 'UP' button on controller to speed up the concentrate motor.
11. Set 10 seconds timer and dispense concentrate by pulling the Left Tap Handle until target value from #6 is within +/- 2 grams of target.
12. Turn water on to machine.
13. Pull Left Tap Handle for 10 seconds until coffee is dispensed.
14. Pull Right Tap Handle for 10 seconds until coffee is dispensed.

## CLEANING AND SANITIZING

### CLEAN SPLASH ZONES AND DISPENSE NOZZLES

1. On a daily basis, using a clean, damp cloth, clean the external cabinet and splash areas including the door gasket. Remove and wash the cup rest and drip tray using mild dish soap.
2. Remove the dispense nozzles by rotating each 90° and pulling down. Remove the mixing chambers by pulling straight forward. Wash using mild dish soap.

**IMPORTANT: DO NOT wash nozzles or mixing chambers in a dish washer. This will distort the plastic and damage the o-rings. Additionally, do not soak them in sanitizing solution longer than 2 minutes.**

### WEEKLY

Check concentrate to water TDS ratio (refer to the **Checking/Adjusting the Ratio TDS Setting** section, Page 13).

### SANITIZER PRODUCT

KAY-5® Sanitizer

Mix one 1 oz. (0.03 liters) packets of Kay-5® Sanitizer solution (or similar brand) in 0.75 gallons (3.84 liters) of tap water to insure 330 PPM of available chlorine.

**IMPORTANT: Use tap water at 75-95°F (23.89-35°C). Water above this range breaks down the chlorine count and minimizes sanitation.**

### CLEANER PRODUCT

Recommended Cleaner: Clearly Cold - Cold Brew Equipment Cleaner.

Mix 0.75 Oz (20 ml) of clearly cold into 5 Gallons (18.9 liters) of water.



Figure 11

Before using the CNB Mini unit for product dispensing and on an ongoing basis, dispenser must be cleaned and sanitized.





Sanitize the dispenser thoroughly (internally and exterior surfaces) by using one of the cleaners listed.





For the cleaning process, have the following ready: Two, 1 gallon food grade buckets / containers, one white cleaning screw in adapter and approved Sanitizer.

To clean and sanitize the unit, perform the procedure in below table.



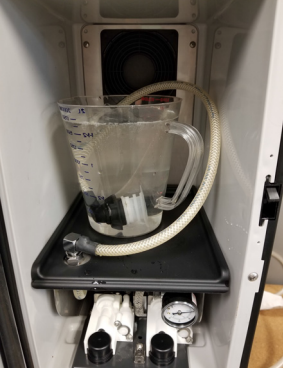

**NOTE: It is recommended that the cleaning be performed weekly, but local codes and regulations must be followed for frequency of cleaning procedures.**



**Table 4**

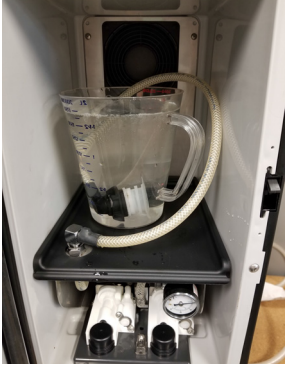

Step	Action	
1	Open the cabinet door (front door).	 <p data-bbox="1161 646 1274 682"><b>Figure 12</b></p>
2	A. Disconnect the product output connector from the BIB (Bag in Box product) by turning the BLACK threaded connector counterclockwise and lifting on the outside of the BLACK connector B. Remove the BIB from the unit	 <p data-bbox="1161 1060 1274 1102"><b>Figure 13</b></p>
3	Connect the white cleaning screw in adapter to the BLACK product output connector by turning the threaded connector clockwise.	 <p data-bbox="1161 1480 1274 1522"><b>Figure 14</b></p>
4	Using a clean and empty food-grade container: Prepare approximately 0.5 gallons (1.9 liters) of warm water. Place the container of water inside the cabinet.	 <p data-bbox="1161 1942 1274 1978"><b>Figure 15</b></p>



Step	Action	
5	Place the BLACK product output connector with the WHITE cleaning adapter inside the food-grade container so that the connector will stay at the bottom.	 <p data-bbox="1084 653 1192 678">Figure 16</p>
6	Set the dispense motor switch on the back of the door to "Clean Mode"	 <p data-bbox="1084 1083 1192 1108">Figure 17</p>
7	Remove drip tray, Place container below nozzles to capture product.	 <p data-bbox="1084 1549 1192 1575">Figure 18</p>
8	<p data-bbox="232 1623 824 1682">A. Open LEFT Tap Handle and dispense 0.25 gallons (0.95 liters) of warm water.</p> <p data-bbox="232 1696 431 1722">B. Close the tap.</p> <p data-bbox="232 1736 792 1795">C. Open RIGHT Tap Handle and dispense 0.25 gallons (0.95 liters) of warm water.</p> <p data-bbox="232 1810 431 1835">D. Close the tap.</p> <p data-bbox="329 1854 786 1948"><b>NOTE: Do not open both valves at the same time as dispensing may pulse or even stop.</b></p>	 <p data-bbox="1084 1959 1192 1984">Figure 19</p>

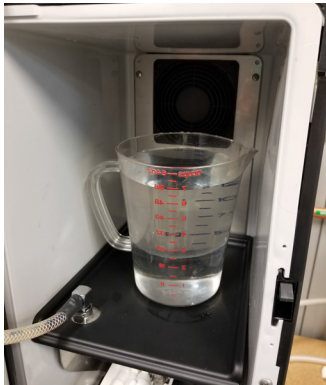

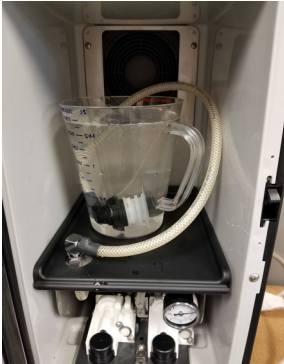



Step	Action	
9	Remove the bucket of water from inside the cabinet and dispose of the remaining water.	 <p data-bbox="1159 663 1268 695"><b>Figure 20</b></p>
10	<p data-bbox="305 768 878 919">Using a clean and empty food-grade container: Prepare any of the listed cleaner solution from the “<b>cleaner products</b>” section above. Place the container of cleaner solution inside the cabinet storage area.</p> <p data-bbox="402 936 894 999"><b>NOTE: Mix thoroughly until all cleaner is dissolved in the solution.</b></p>	 <p data-bbox="1159 1094 1268 1125"><b>Figure 21</b></p>
11	Place the BLACK product output connector with the WHITE cleaning adapter inside the food-grade container so that the connector will stay at the bottom.	 <p data-bbox="1159 1535 1268 1566"><b>Figure 22</b></p>
12	Remove drip tray, Place container below nozzles to capture product.	 <p data-bbox="1159 1965 1268 1997"><b>Figure 23</b></p>

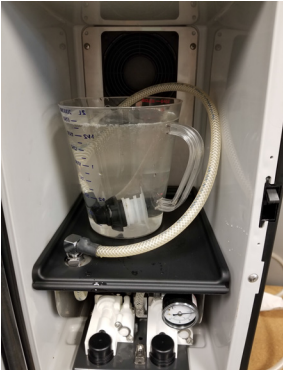
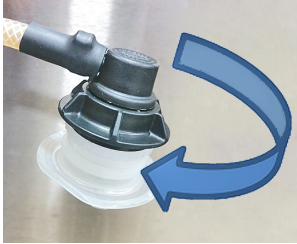

Step	Action	
13	<p>A. Open LEFT Tap Handle and dispense 0.25 gallons (0.95 liters) of cleaner solution.</p> <p>B. Close the tap.</p> <p>C. Open RIGHT Tap Handle and dispense 0.25 gallons (0.95 liters) of cleaner solution.</p> <p>D. Close the tap.</p> <p><b>NOTE: Do not open both valves at the same time as dispensing may pulse or even stop.</b></p>	 <p style="text-align: center;"><b>Figure 24</b></p>
14	<p>With the taps straight up (closed), allow cleaner solution to soak in the lines for 5 minutes.</p>	 <p style="text-align: center;"><b>Figure 25</b></p>
15	<p>A. Open LEFT Tap Handle and dispense 0.25 gallons (0.95 liters) of cleaner solution.</p> <p>B. Close the tap.</p> <p>C. Open RIGHT Tap Handle and dispense 0.25 gallons (0.95 liters) of cleaner solution.</p> <p>D. Close the tap.</p> <p><b>NOTE: Do not open both valves at the same time as dispensing may pulse or even stop.</b></p>	 <p style="text-align: center;"><b>Figure 26</b></p>
16	<p>Remove the bucket of cleaner solution from inside the cabinet and dispose of the remaining cleaner solution.</p>	 <p style="text-align: center;"><b>Figure 27</b></p>

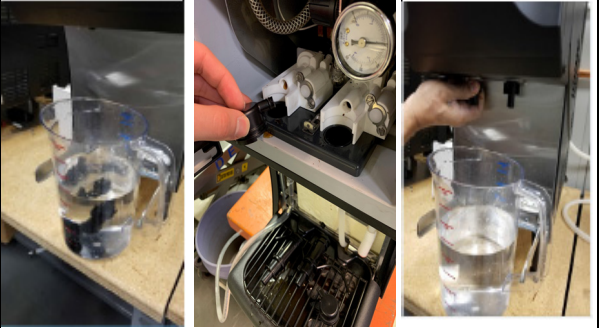
Step	Action	
17	<p>Using a clean and empty food-grade container: Prepare any of the listed sanitizer solution from the “<b>sanitizer products</b>” section above. Place the container of sanitizer solution inside the cabinet storage area.</p> <p><b>NOTE: Mix thoroughly until all sanitizer is dissolved in the solution.</b></p>	 <p><b>Figure 28</b></p>
18	<p>Place the BLACK product output connector with the WHITE cleaning adapter inside the food-grade container so that the connector will stay at the bottom.</p>	 <p><b>Figure 29</b></p>
19	<p>Remove drip tray, Place container below nozzles to capture product.</p>	 <p><b>Figure 30</b></p>
20	<p>A. Open LEFT Tap Handle and dispense 0.25 gallons (0.95 liters) of sanitizer solution. B. Close the tap. C. Open RIGHT Tap Handle and dispense 0.25 gallons (0.95 liters) of sanitizer solution. D. Close the tap.</p> <p><b>NOTE: Do not open both valves at the same time as dispensing may pulse or even stop.</b></p>	 <p><b>Figure 31</b></p>

Step	Action	
21	<p>With the taps straight up (closed), allow sanitizer solution to soak in the lines for 20 minutes.</p>	 <p style="text-align: center;"><b>Figure 32</b></p>
22	<p>A. Open LEFT Tap Handle and dispense 0.25 gallons (0.95 liters) of sanitizer solution.                      B. Close the tap.                      C. Open RIGHT Tap Handle and dispense 0.25 gallons (0.95 liters) of sanitizer solution.                      D. Close the tap.</p> <p style="text-align: center;"><b>NOTE: Do not open both valves at the same time as dispensing may pulse or even stop.</b></p>	 <p style="text-align: center;"><b>Figure 33</b></p>
23	<p>Remove the bucket of sanitizer solution from inside the cabinet and use it for cleaning the nozzle and mixing chamber.</p>	 <p style="text-align: center;"><b>Figure 34</b></p>
24	<p>Disconnect the WHITE cleaning adapter from the BLACK product output connector by turning the BLACK connector counterclockwise and lifting on the outside of the BLACK connector.</p>	 <p style="text-align: center;"><b>Figure 35</b></p>



Step	Action	
25	<p>Remove Left and Right nozzles, along with both mixing chambers and place in sanitizer bucket for 2 minutes.</p>	 <p style="text-align: center;"><b>Figure 36</b></p>
26	<p>Replace both mixing chambers, Left, and Right nozzles.</p> <p><b>NOTE: Check that o-rings are on the mixing chamber and dispense nozzles.</b></p>	 <p style="text-align: center;"><b>Figure 37</b></p>
27	<p>A. Obtain a product BIB.</p> <p>B. Place it in the cabinet, outlet port towards the base of the cabinet, and connect the BLACK product output connector by turning the threaded connector ring clockwise. Be sure the connector is screwed on completely.</p> <p>C. Close the cabinet door.</p>	 <p style="text-align: center;"><b>Figure 38</b></p>
28	<p>Change the Dispense motor switch position to 'on' from clean mode.</p>	 <p style="text-align: center;"><b>Figure 39</b></p>

Step	Action	
29	<p>A. Open LEFT Tap Handle to pour 16Oz (until coffee comes out).</p> <p>B. Close the Tap.</p> <p>C. Open RIGHT Tap Handle to pour 8Oz (until coffee comes out).</p> <p>D. Close the tap.</p> <p><b>NOTE: Do not open both valves at the same time as dispensing may pulse or even stop.</b></p>	 <p data-bbox="1084 646 1192 674"><b>Figure 40</b></p>
30	<p><b>The sanitizing procedure is complete.</b></p>	 <p data-bbox="1084 1083 1192 1110"><b>Figure 41</b></p>

# CHANGING COFFEE TYPES



In some cases the type of coffee used in the CNB Mini unit may require an adjustment of the height of the foam head for proper presentation. If this adjustment is required, it should be performed by a manager or technician who is trained in the operation of the CNB Mini unit.

## UNIT FOAM HEAD HEIGHT ADJUSTMENT

**NOTE: Follow all previous INSTALLATION and CLEANING/SANITATION section processes before continuing with this section.**

Once the equipment has been installed, cleaned, and sanitized, perform the procedure refer below Table to adjust the foam head height on the CNB Mini unit.

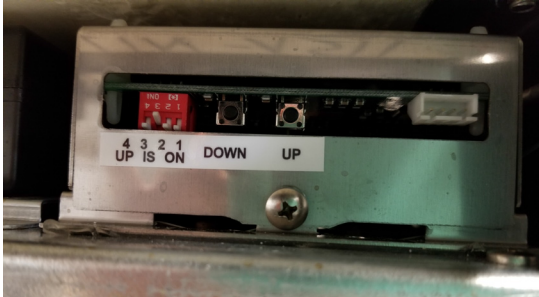
Table 5

Step	Action	
1	<p>Inside the cabinet, ensure dispense motor switch is at <b>"ON position"</b>. Dip switch on the PCB behind the splash panel is set as per product requirement.</p>	 <p>Figure 42</p>
2	<p>Locate the secondary Nitrogen regulator behind the pump deck door inside the cabinet. <b>Adjust only the regulator shown.</b></p>	 <p>Figure 43</p>

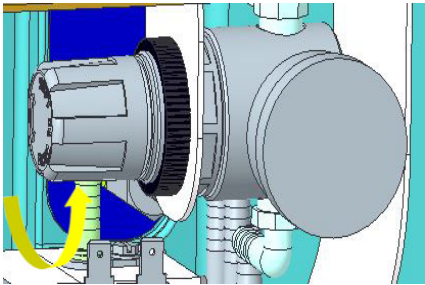
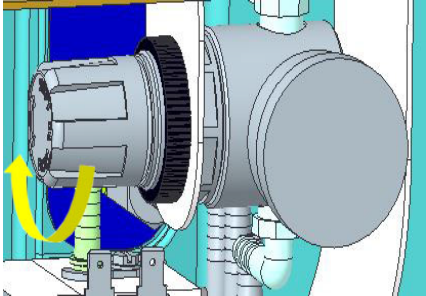
Step	Action	
3	<p><b>REDUCED FOAM HIGHT</b> adjustment:</p> <p>A. Pull out regulator control knob to unlock for adjustments.</p> <p>B. Adjust the regulator control knob slightly (approximately 1/8th of a turn) to the <b>LEFT</b> (counter-clockwise). Only very fine adjustments are required. This <b>reduces</b> the amount of Nitrogen injected.</p> <p>C. Push regulator control knob in to lock set pressure.</p> <p>D. Open the <b>RIGHT</b> Tap Handle and dispense about 8 oz. of product to drain the line of product at the previous foam setting. Then dispense 12 oz. of product and confirm the foam head height. Repeat and dispense another 12 oz. to confirm setting.</p> <p>E. Repeat step A if a further reduction of foam head height is required.</p>	 <p style="text-align: center;"><b>Figure 44</b></p>
4	<p><b>INCREASED FOAM HIGHT</b> adjustment:</p> <p>A. Pull out regulator control knob to unlock for adjustments.</p> <p>B. Adjust the regulator control knob slightly (approximately 1/8th of a turn) to the <b>RIGHT</b> (clockwise). Only very fine adjustments are required. This increases the amount of Nitrogen injected.</p> <p>C. Push regulator control knob in to lock set pressure.</p> <p>D. Open the <b>RIGHT</b> Tap Handle and dispense about 8 oz. of product to drain the line of product at the previous foam setting. Then dispense 12 oz. of product and confirm the foam head height. Repeat and dispense another 12 oz. to confirm setting.</p> <p>E. Repeat step A if a further increase of foam head height is required.</p>	 <p style="text-align: center;"><b>Figure 45</b></p>
5	<p>Reinstall the regulator access cover.</p>	<p style="text-align: center;"><b>Figure 46</b></p>





# SYSTEM ELECTRICAL DIAGRAM

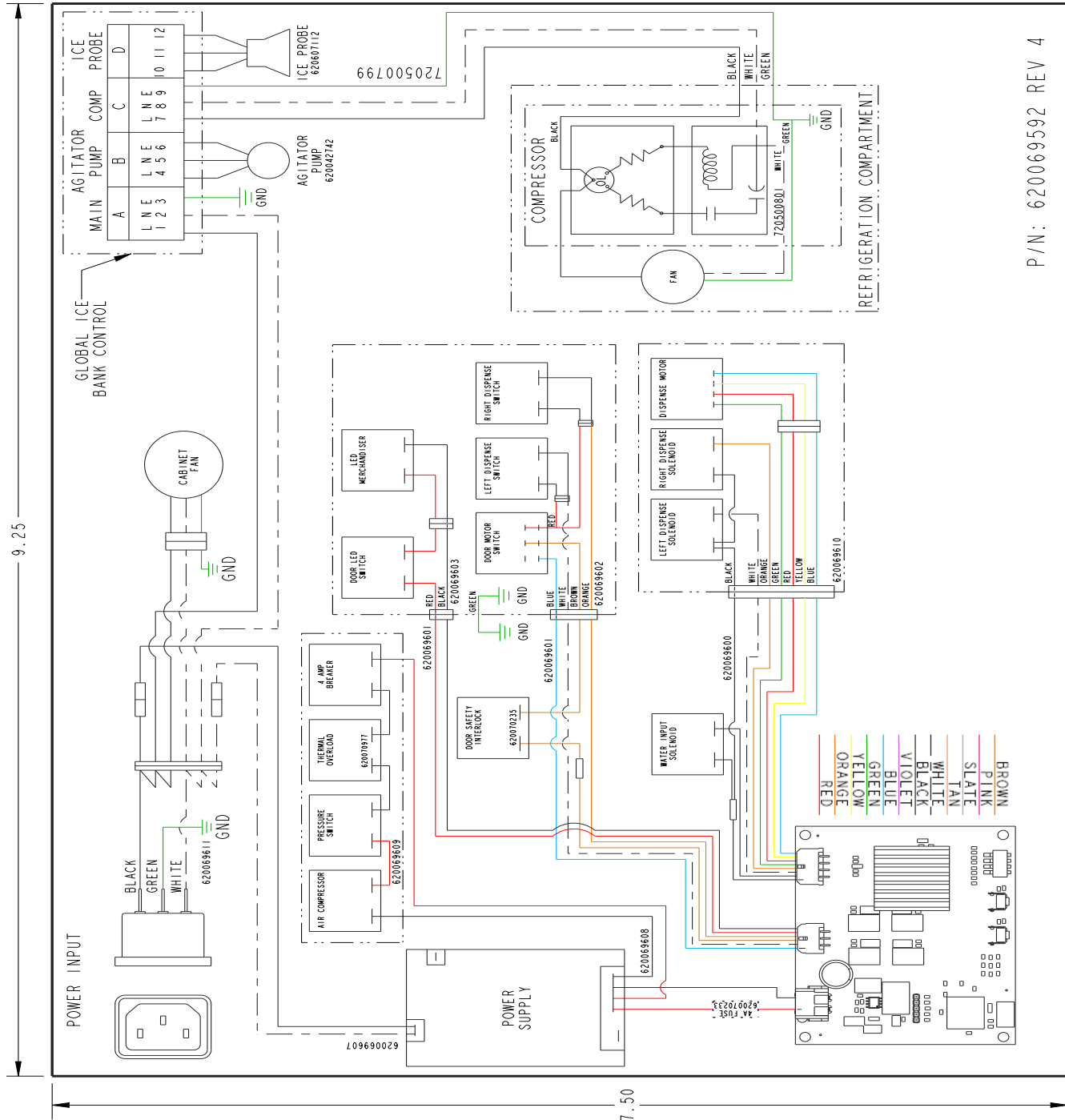

P/N: 620069592 REV 4

Figure 47

# SYSTEM PLUMBING SCHEMATIC

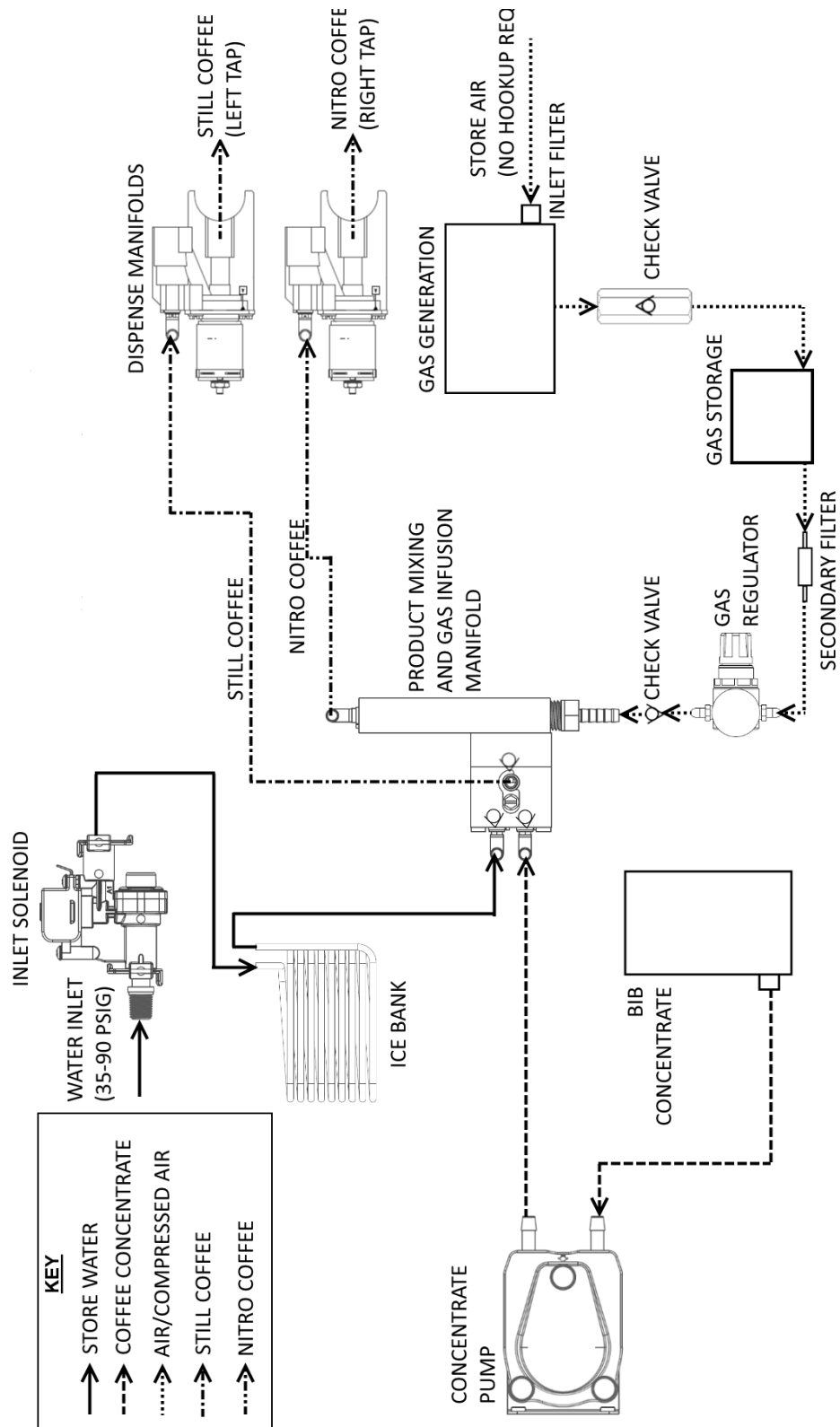

Figure 48





**Cornelius Inc.**  
**[www.cornelius.com](http://www.cornelius.com)**