



STANDARD EQUIPMENT POST-MIX VALVE

SFV-1™



FEATURES

- Durable** - Rugged and reliable
- Dependable** - Accurate brix control with superior repeatability
- Accommodating** - Modular design for simplified maintenance
- Easy to use** - Easy to change flow rate and activation methods

- Quality** - Corrosion-free stainless steel valve lever
- Reliable** - Improved ratio control reduces service calls
- Serviceability** - Minimum number of fasteners allows for quick service
- Option** - Forward and downward LED lighting for sanitary lever configuration only



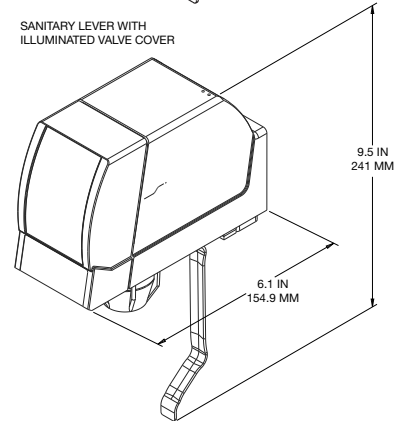
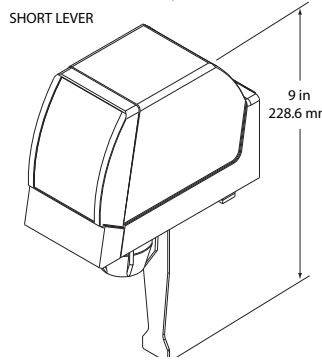
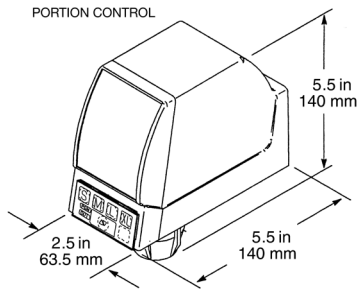
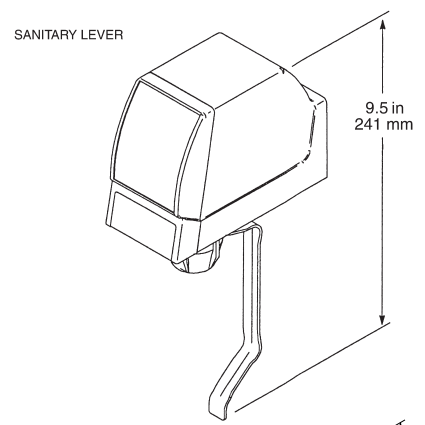
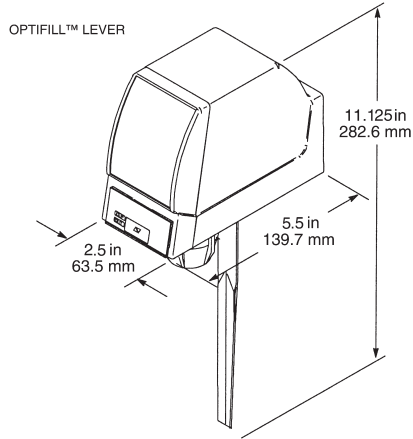
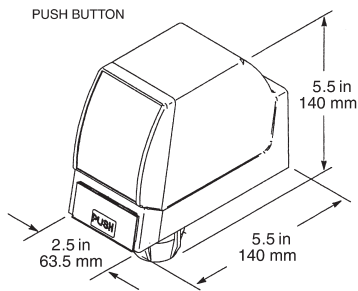

PART NUMBER	DESCRIPTION
620608766	Sanitary Lever Valve, ceramic regulator, without mounting block and covers
620608761	Sanitary Lever Valve, ceramic regulator, with mounting block and covers
620608767	Push Button Valve, ceramic regulator, without mounting block and covers
620608762	Push Button Valve, ceramic regulator, with mounting block and covers
620609132	Short Lever Valve, ceramic regulator, without mounting block and covers
620609131	Short Lever Valve, ceramic regulator, with mounting block and covers
620608768	Portion Control Valve without mounting block and cover
620608763	Portion Control Valve with mounting block and cover
620608769	Optifill™ Lever Valve, ceramic regulator, without mounting block and covers
620608764	Optifill™ Lever Valve, ceramic regulator, with mounting block with covers
620066649	Illuminated Sanitary Lever Valve, ceramic regulator, without mounting block and covers
620066650	Illuminated Sanitary Lever Valve, ceramic regulator, with mounting block and covers
629097630	Conversion Kit, Illuminated Sanitary Lever

TECHNICAL SPECIFICATIONS

FLOW RATE 1.5 - 3 oz/sec (45-90 mL)

OPERATIONAL RELATIVE

HUMIDITY RANGE 20-100%

OPERATIONAL

TEMPERATURE RANGE 32°-140°F
(0°-60°C)

ELECTRICAL REQUIREMENTS . . 24 V / 50 Hz 60 Hz

SHIPPING WEIGHT 34 lb (carton of 20)

GRAPHIC SIZE Front: 2.91"H x 1.9"(top)
x 2"(bottom)
Back: 1.22"H x 1.97"(top)
x 2"(bottom)

AGENCY LISTINGS



Coca-Cola and Coca-Cola Classic are registered trademarks of the Coca-Cola Company.



© 2017 CORNELIUS

CC5003-0317

IN THE U.S.A.
Ph: 800.238.3600
Fax: 763.488.4283

OUTSIDE THE U.S.A.
Ph: 763.488.8200
Email: webmaster@cornelius.com

101 Broadway Street West
Osseo, MN 55369
www.cornelius.com

For more information or to place an order, contact your sales representative or authorized distributor.