

---

# IDC 255 PROGATE DRIVE THRU

## Service Manual

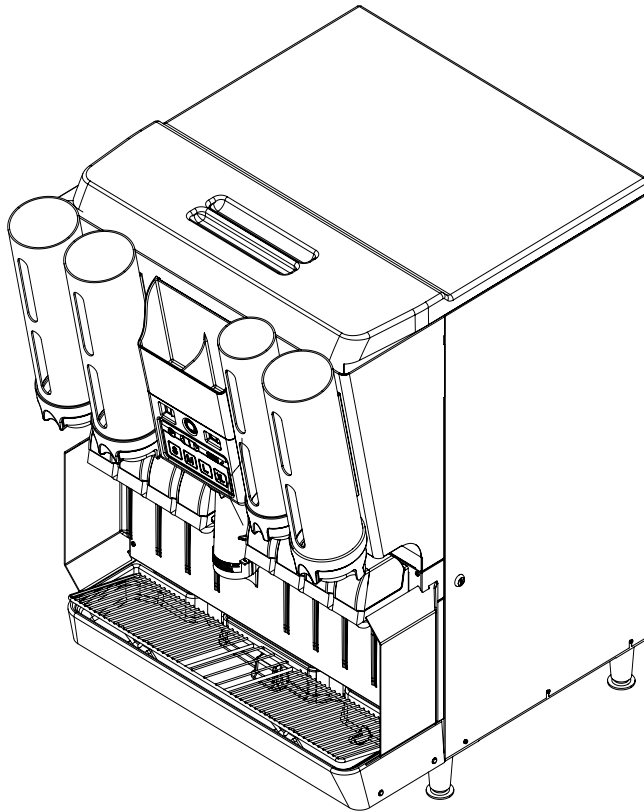

**Release Date: June 27, 2006**

**Publication Number: 621057419SER**

**Revision Date: April 02, 2014**

**Revision: F**

Visit the Cornelius web site at [www.cornelius.com](http://www.cornelius.com) for all your Literature needs.

---

The products, technical information, and instructions contained in this manual are subject to change without notice. These instructions are not intended to cover all details or variations of the equipment, nor to provide for every possible contingency in the installation, operation or maintenance of this equipment. This manual assumes that the person(s) working on the equipment have been trained and are skilled in working with electrical, plumbing, pneumatic, and mechanical equipment. It is assumed that appropriate safety precautions are taken and that all local safety and construction requirements are being met, in addition to the information contained in this manual.

This Product is warranted only as provided in Cornelius' Commercial Warranty applicable to this Product and is subject to all of the restrictions and limitations contained in the Commercial Warranty.

Cornelius will not be responsible for any repair, replacement or other service required by or loss or damage resulting from any of the following occurrences, including but not limited to, (1) other than normal and proper use and normal service conditions with respect to the Product, (2) improper voltage, (3) inadequate wiring, (4) abuse, (5) accident, (6) alteration, (7) misuse, (8) neglect, (9) unauthorized repair or the failure to utilize suitably qualified and trained persons to perform service and/or repair of the Product, (10) improper cleaning, (11) failure to follow installation, operating, cleaning or maintenance instructions, (12) use of "non-authorized" parts (i.e., parts that are not 100% compatible with the Product) which use voids the entire warranty, (13) Product parts in contact with water or the product dispensed which are adversely impacted by changes in liquid scale or chemical composition.

### **Contact Information:**

To inquire about current revisions of this and other documentation or for assistance with any Cornelius product contact:

**[www.cornelius.com](http://www.cornelius.com)**

**800-238-3600**

### **Trademarks and Copyrights:**

This document contains proprietary information and it may not be reproduced in any way without permission from Cornelius.

This document contains the original instructions for the unit described.

CORNELIUS INC  
101 Regency Drive  
Glendale Heights, IL  
Tel: + 1 800-238-3600

Printed in U.S.A.

---

# TABLE OF CONTENTS

<b>Safety Instructions</b> .....	<b>1</b>
Read and Follow ALL Safety Instructions .....	1
Safety Overview .....	1
Recognition .....	1
Different Types of Alerts .....	1
Safety Tips .....	1
Qualified Service Personnel .....	1
Safety Precautions .....	2
Shipping And Storage .....	2
CO2 (Carbon Dioxide) Warning .....	2
Mounting in or on a Counter .....	2
<b>Unit Specification</b> .....	<b>3</b>
Description .....	3
Valve Configurations .....	3
Specification .....	3
Progate 2 Features .....	4
Progate Portion Ice Control Features .....	4
Lid Dispenser .....	4
Straw Holder .....	4
LID HOLDER COMPATIBILITY .....	4
Small Lid Template .....	5
Medium Lid Template .....	6
Large Lid Template .....	7
Lid Dispenser Maintenance .....	8
Progate 2 Control Box Operation .....	8
Portion Control Box Functions .....	8
Programming (Changing) the Ice Portion .....	9
Agitation Time .....	9
Programming (Changing) the Agitation Time .....	10
Ice Portion Bar .....	11
<b>Diagrams</b> .....	<b>12</b>
Cold Plate .....	12
7 Intelli Valves and 1 Variety Valve .....	12
8 Intelli Valves or 8 UFB-1 Valves .....	13
E – Board Off Cycle Agitation Adjustments .....	14
Electrical Schematic .....	15
Main Electrical Box Assembly .....	16
Interconnect Schematic .....	17
<b>CLEANING AND MAINTENANCE INSTRUCTIONS</b> .....	<b>18</b>

---

Daily Cleaning: . . . . .	18
Daily Maintenance: . . . . .	18
Weekly Cleaning: (In addition to daily procedures) . . . . .	18
Monthly Cleaning: (In addition to daily and weekly procedures) . . . . .	18
Yearly Maintenance: . . . . .	19
Lid Dispenser Cleaning . . . . .	19
Ice Chute Cleaning . . . . .	19
Removing and Reinstalling the Ice Chute: . . . . .	19
Cleaning Interior Surfaces (Monthly Cleaning) . . . . .	19
Cold Plate (Yearly Maintenance) . . . . .	20
Dispensing Valves: (Daily Cleaning) . . . . .	20
Product Tubing (Monthly Cleaning) . . . . .	20
Sanitize Pre-Mix And Post-Mix Tank System . . . . .	20
Sanitize syrup lines, B-I-B Systems . . . . .	21
Replenishing CO2 Supply (As Required). . . . .	21
<b>SERVICE . . . . .</b>	<b>22</b>
Merchandiser Removal . . . . .	22
Control Box Removal . . . . .	23
Main Electrical Box Access . . . . .	23
Ice Chute Removal . . . . .	24
Diagnostics Guide for the Main Control Board. . . . .	25
Motor Removal. . . . .	25
<b>Troubleshooting. . . . .</b>	<b>27</b>
Power Light Off . . . . .	27
No Ice Dispense in Manual Mode . . . . .	28
No Ice Dispense in Automatic Mode . . . . .	29
Beverage Not Dispensing . . . . .	30
Flat Drinks . . . . .	31
No Carbonated Water . . . . .	32

# SAFETY INSTRUCTIONS

## READ AND FOLLOW ALL SAFETY INSTRUCTIONS

### Safety Overview

- Read and follow **ALL SAFETY INSTRUCTIONS** in this manual and any warning/caution labels on the unit (decals, labels or laminated cards).
- Read and understand ALL applicable OSHA (Occupational Safety and Health Administration) safety regulations before operating this unit.

### Recognition

<i>Recognize Safety Alerts</i>
 <p><i>This is the safety alert symbol. When you see it in this manual or on the unit, be alert to the potential of personal injury or damage to the unit.</i></p>

## DIFFERENT TYPES OF ALERTS

### **DANGER:**

Indicates an immediate hazardous situation which if not avoided **WILL** result in serious injury, death or equipment damage.

### **WARNING:**

Indicates a potentially hazardous situation which, if not avoided, **COULD** result in serious injury, death, or equipment damage.

### **CAUTION:**

Indicates a potentially hazardous situation which, if not avoided, **MAY** result in minor or moderate injury or equipment damage.

## SAFETY TIPS

- Carefully read and follow all safety messages in this manual and safety signs on the unit.
- Keep safety signs in good condition and replace missing or damaged items.
- Learn how to operate the unit and how to use the controls properly.
- **Do not** let anyone operate the unit without proper training. This appliance is **not** intended for use by very young children or infirm persons without supervision. Young children should be supervised to ensure that they do not play with the appliance.
- Keep your unit in proper working condition and do not allow unauthorized modifications to the unit.

## QUALIFIED SERVICE PERSONNEL

### **WARNING:**

Only trained and certified electrical, plumbing and refrigeration technicians should service this unit. **ALL WIRING AND PLUMBING MUST CONFORM TO NATIONAL AND LOCAL CODES. FAILURE TO COMPLY COULD RESULT IN SERIOUS INJURY, DEATH OR EQUIPMENT DAMAGE.**

## SAFETY PRECAUTIONS

This unit has been specifically designed to provide protection against personal injury. To ensure continued protection observe the following:

### **WARNING:**

Disconnect power to the unit before servicing following all lock out/tag out procedures established by the user. Verify all of the power is off to the unit before any work is performed.

**Failure to disconnect the power could result in serious injury, death or equipment damage.**

### **CAUTION:**

Always be sure to keep area around the unit clean and free of clutter. Failure to keep this area clean may result in injury or equipment damage.

## SHIPPING AND STORAGE

### **CAUTION:**

Before shipping, storing, or relocating the unit, the unit must be sanitized and all sanitizing solution must be drained from the system. A freezing ambient environment will cause residual sanitizing solution or water remaining inside the unit to freeze resulting in damage to internal components.

## CO<sub>2</sub> (CARBON DIOXIDE) WARNING

### **DANGER:**

CO<sub>2</sub> displaces oxygen. Strict attention **MUST** be observed in the prevention of CO<sub>2</sub> gas leaks in the entire CO<sub>2</sub> and soft drink system. If a CO<sub>2</sub> gas leak is suspected, particularly in a small area, **IMMEDIATELY** ventilate the contaminated area before attempting to repair the leak. Personnel exposed to high concentrations of CO<sub>2</sub> gas experience tremors which are followed rapidly by loss of consciousness and **DEATH**.

## MOUNTING IN OR ON A COUNTER

### **WARNING:**

When installing the unit in or on a counter top, the counter must be able to support a weight in excess of **615 lbs.** to ensure adequate support for the unit.

**FAILURE TO COMPLY COULD RESULT IN SERIOUS INJURY, DEATH OR EQUIPMENT DAMAGE.**

**NOTE:** Many units incorporate the use of additional equipment such as icemakers. When any addition equipment is used you must check with the equipment manufacturer to determine the additional weight the counter will need to support to ensure a safe installation.



# UNIT SPECIFICATION

## DESCRIPTION

The Ice Drink Cornelius (IDC) series of dispensers solves your ice and beverage service needs in a sanitary, space saving, economical way. Designed to be manually filled with ice from any remote ice-making source, these dispensers will dispense cubes (up to 1-1/4 inch in size), cubelets, and compressed (not flaked). In addition, the units include beverage faucets, a cold plate, an internal carbonator tank and an external pump for the carbonator, and are designed to be supplied direct from syrup tanks with no additional cooling required.

## VALVE CONFIGURATIONS

- IDC 255 Progate Drive Thru Unit with 7 Intelli Valves and 1 Variety Valve
- IDC 255 Progate Drive Thru Unit with 8 Intelli Valves
- IDC 255 Progate Drive Thru Unit with 8 UFB-1 Valves

## SPECIFICATION

Model Descriptions	IDC 255 B=Beverage C=Coldplate H=Internal Carb P=Progate Z=No Drip Tray
Unit Weight	368 Pounds
Ice Storage	255 Pounds
Maximum Number of Faucets	10
Built-in Cold Plate	Yes
Electrical	120/1/60 9.3 Amps of Total Unit Draw OR 220/1/50 4.7 Amps of Total Unit Draw
Dimensions	Width 29.90 inch (.76 m) Height 39.75 inch (1.0 m) Depth 36.90 inch (.94 m)
CO2 Operating Pressure	75-psig (max)
Water	100 psi (7 bar) maximum static pressure. 40 psi (2.8 bar) minimum dynamic pressure. 3/8" minimum water line recommended.

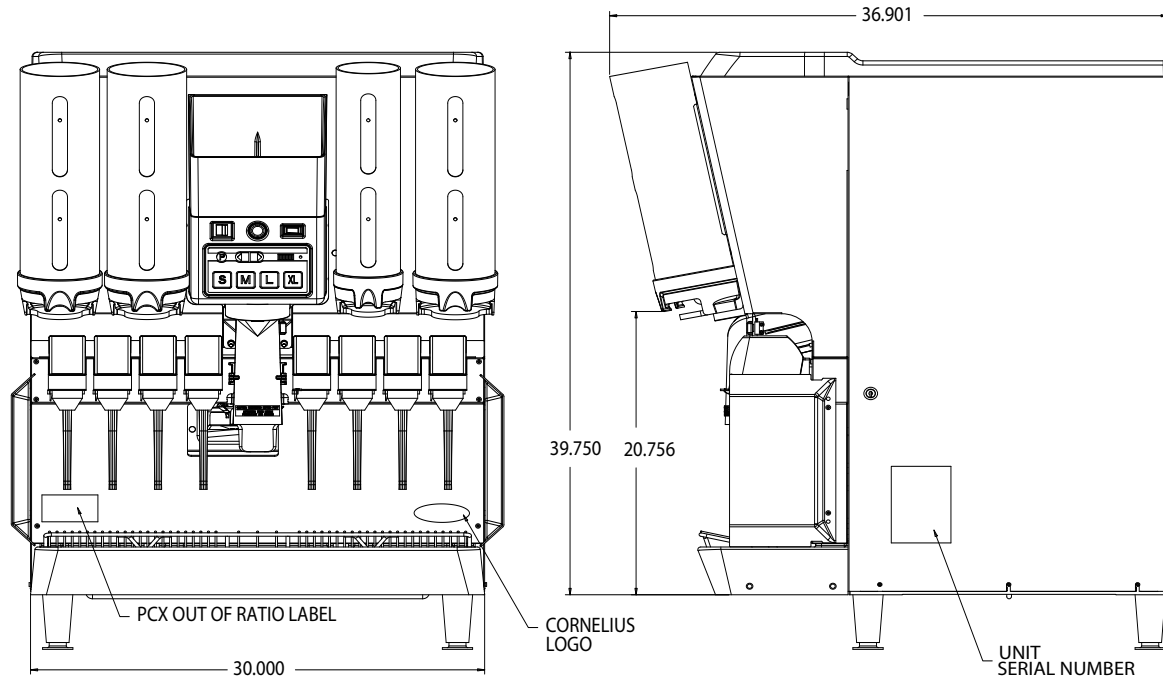

**Figure 1.**

**Electrical Connections:** 6 ft long power cord with 3-prong plug attached to dispenser.

**Power Requirements:** 9.3 amps at 120 volts dedicated power supply.

**Water Supply Requirements:** 100 psi (7 bar) maximum static pressure 40 psi (28 bar) minimum dynamic pressure. 3/8" minimum water line recommended.

**CO2 Requirements:** 100 psi max to unit regulated to 35 psi (2.4 bar) to Progate 2 ice gate system, 75 psi (5.2 bar) carbonator.

## PROGATE 2 FEATURES

### Progate Portion Ice Control Features

- 4 Programmable ice dispense sizes
- Automatic/Manual Ice Dispense Modes
- Unit Power On/Off Switch
- Programmable Agitation Time

### Lid Dispenser

- 4 lid dispenser locations on the unit
- 3 Separate removable lid dispensers for small/medium, large, and extra large lids

### Straw Holder

- Holds up to 140 regular sleeved straws

## LID HOLDER COMPATIBILITY

The following template is a guide to validate the compatibility of the cup lids that are used with the Cornelius Lid Dispensers supplied with the IDC255 Progate Ice Drink Dispenser. The lid dispensers accommodate small lids 3.75" in Dia.  $\pm$  .032" in the large lid dispensers. The templates below are to scale to check the lids or compatibility.



### Small Lid Template

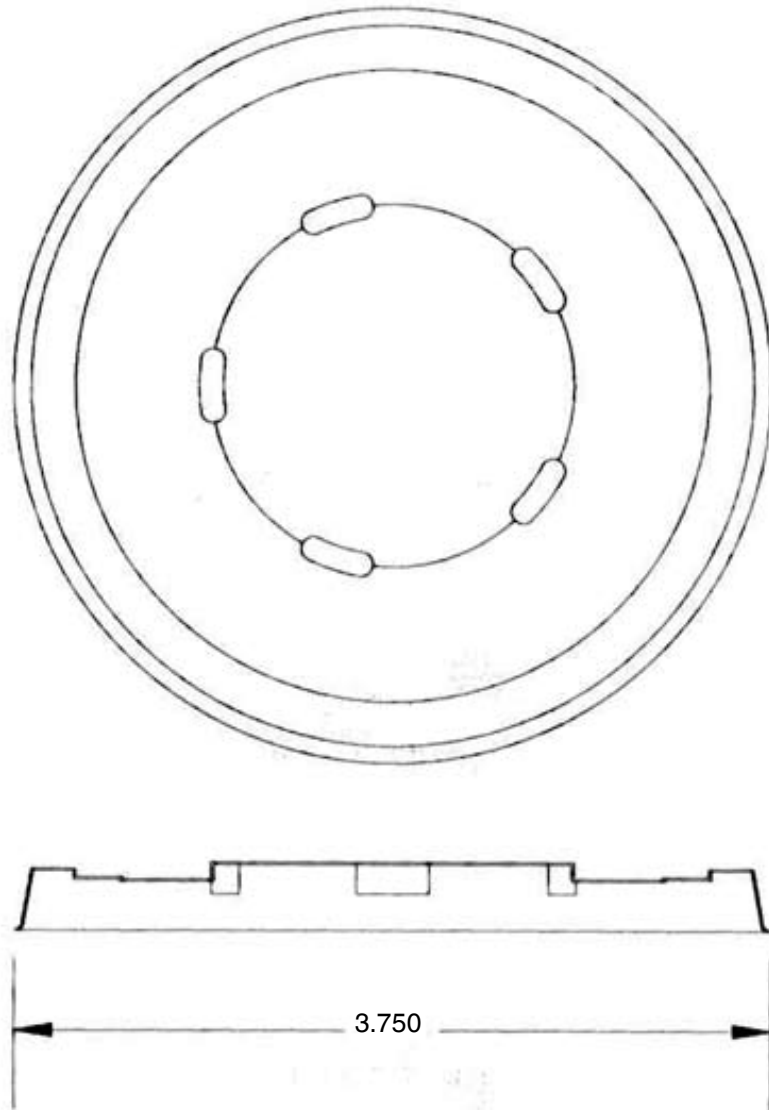

Figure 2.

## Medium Lid Template

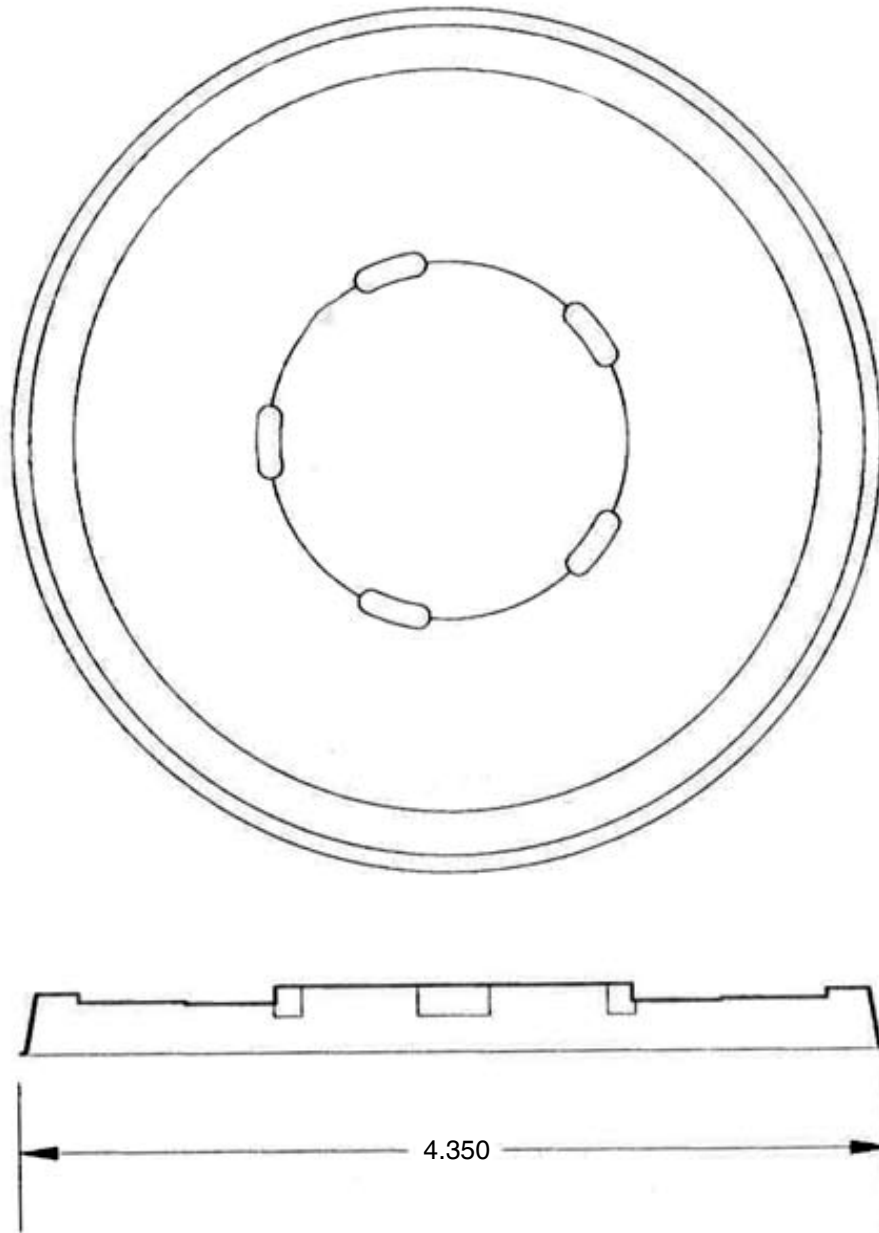

Figure 3.

## Large Lid Template

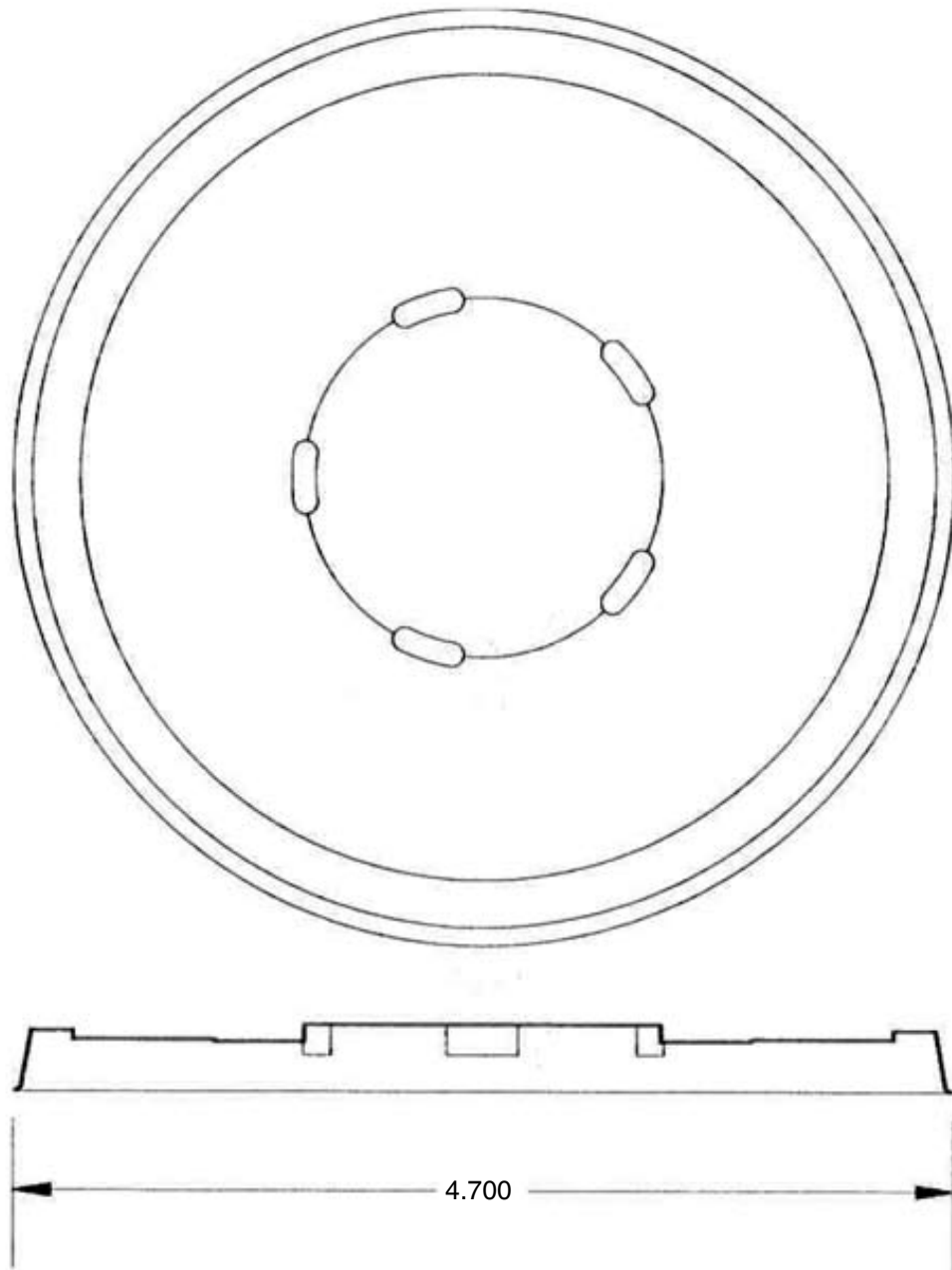

Figure 4.

## LID DISPENSER MAINTENANCE

The lid dispensers are manufactured out of materials that can survive chlorine-based cleaners and warm water <100°F. Ensure that the parts are thoroughly dried before refilling with lids.

**NOTE: Lid dispenser parts should not be soaked in the powersoak washing machine as this will result in the parts getting scratched. Instead the dispenser parts should be rinsed in warm soap water and then dried.**

## PROGATE 2 CONTROL BOX OPERATION

### Portion Control Box Functions

The portion control box on the PROGATE 2 has several functions including dispensing 4 programmed ice portions for 4 cup sizes, programming and a manual dispense mode.

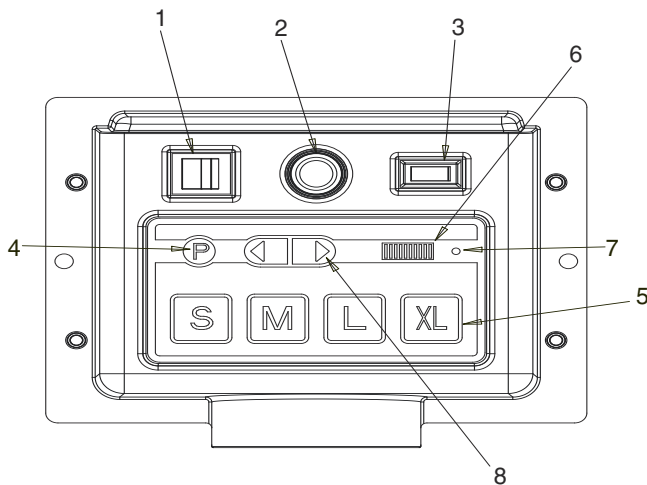







1. MAIN POWER ON/OFF
2. AGITATOR PUSH ON
3. MODE SWITCH MANUAL/PROGATE
4. PROGRAM BUTTON
5. ICE PORTION DISPENSE BUTTONS
6. ICE PORTION BAR
7. PROGATE ON LIGHT
8. PORTION SIZE LEFT/RIGHT KEYS

1. **Main Power ON/OFF:** Turns power to the entire machine off. Lights Orange when ON.
2. **Agitator Push ON:** Turns on agitator and opens ice gate allowing continuous dispense. This button will turn green in the manual mode and will be off in PROGATE automatic. This button will also agitate in the automatic mode but not dispense ice.
3. **Mode Switch Manual/Progate:** Turns on agitator and opens ice gate allowing unlimited ice portion.
4. **Program Button:** The programming button is used with cup size button enabling the user to enter the portion programming mode to adjust the ice portions. The programming button is used with the directional arrow buttons to adjust the agitation time.
5. **Ice Portion Dispense Buttons:** Used to dispense the appropriate ice portion. Can also be used in conjunction with the program button to program a portion size.
6. **Ice Size Program Bar:** The program bar is only active in the program mode as a visual aid in setting the portion size.
7. **Light:** On start up of the unit or during a mode change (Manual to Progate) this light turns orange to inform the user that the unit is going through a self diagnostic test. On completion of this test the light turns green to inform the user that the machine is ready to dispense. If the light remains solid on red and the unit is not dispensing any ice when an ice portion is pressed this should generate a service call. During ice dispense if there is insufficient ice in the ice chute then the light turns red instantaneously to inform the user that there is insufficient ice. Once the user releases the portioned button then the red light goes out.
8. **Portion Up/Down Buttons:** The program bar is only active in the program mode to change the ice dispense program size.

## Programming (Changing) the Ice Portion

To change the size of any of the four ice dispense sizes follow the steps below.

1. To enter the program mode press the **Program Button**  and **Desired Size button**  at the same time and hold for 5 seconds.
2. The Ice Portion Bar will come on 
3. Press the **RIGHT ARROW button**  to increase the amount of dispensed ice. The LED will move towards the right indicating the Ice Portion has been increased.
4. Press the **LEFT ARROW button**  to decrease the amount of dispensed ice. The LED will move towards the left indicating the Ice Portion has been decreased.
5. To exit the program mode press the **Desired Size button**  or wait 10 seconds and the control will return to the dispense mode.
6. Place a cup under the ice chute and press the just programmed dispense size button  If amount dispense amount is not the desired amount repeat the process.
7. To exit, repeat Step 1.

## Agitation Time

The software coding for the progate system involves a direct relationship between the dispense time and the agitation time.

Dispense Time (mS)	Agitation Ratio	Agitation Time (mS)
50	10	500
70	10	700
90	10	900
110	10	1100
130	10	1300
150	10	1500
170	10	1700
190	10	1900
210	10	2100
230	10	2300

Dispense Time (mS)	Agitation Ratio	Agitation Time (mS)
50	16	800
70	16	1120
90	16	1440
110	16	1760
130	16	2080
150	16	2400

Dispense Time (mS)	Agitation Ratio	Agitation Time (mS)
170	16	2720
190	16	3040
210	16	3360
230	16	3680

Dispense Time (mS)	Agitation Ratio	Agitation Time (mS)
50	28	1400
70	28	1960
90	28	2520
110	28	3080
130	28	3640
150	28	4200
170	28	4760
190	28	5320
210	28	5880
230	28	6440

The relationship is expressed below.

$$\text{Agitation Time (A}_T\text{)} = \text{Dispense Time (D}_T\text{)} \times \text{Agitation Ratio}^2\text{ (R}_A\text{)}$$

The agitation time equals the dispense time multiplied by the agitation ratio. The user is given the flexibility to change the agitation ratio thereby altering the agitation time in order to ensure that the ice chute is always filled with ice for all ice types.

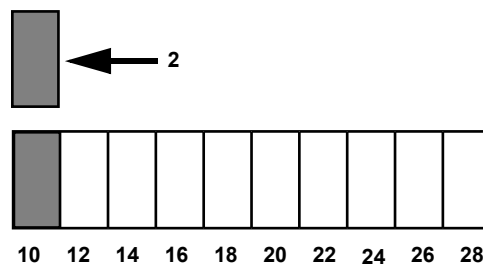

Figure 5.

### Programming (Changing) the Agitation Time

1. Simultaneously press and hold for 3 seconds, the button and also both direction arrow buttons to enter the programming mode.
2. The LED meter turns ON once the programming mode is entered. Visual feedback of ratio/agitation time is obtained from the visual programming LED . The LED meter shows the existing agitation ratio enabling the user to vary the agitation time using the directional arrow buttons. Left to decrease and right direction arrow button to increase.
3. To exit, repeat Step 1.

## Ice Portion Bar

The portion bar is used to determine the amount of time programmed for each size button. Each button has a minimum and maximum amount of time that can be programmed. If a button cannot be adjusted to the size desired use another button to get the desired results.

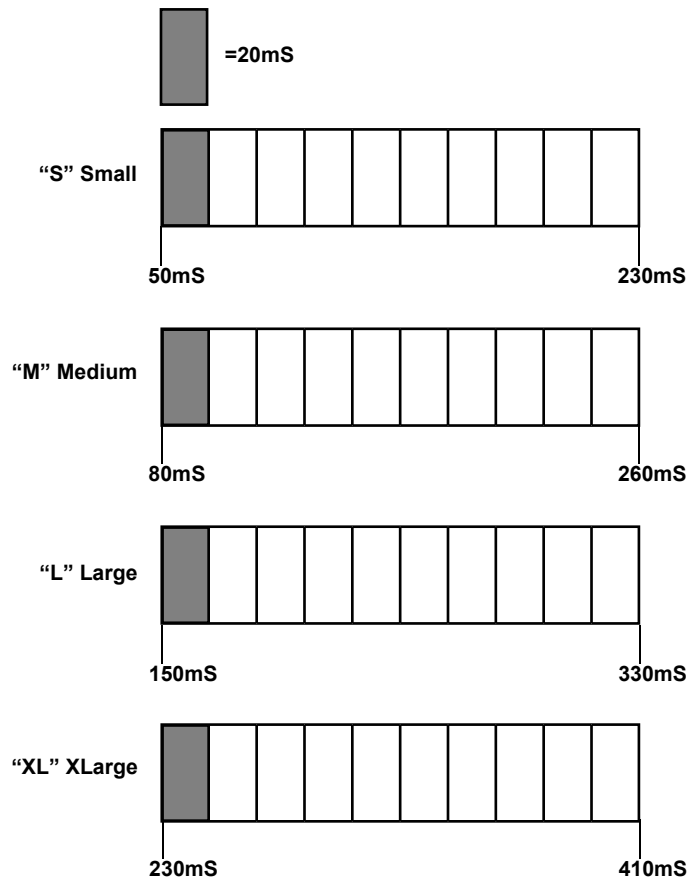

Figure 6.

# DIAGRAMS

## COLD PLATE

The beverage assembly for the unit comprises of 7 Intelli Valves and 1 Variety valve, 8 Intelli Valves, or 8 UFB-1 valves. Attached are the cold plate diagrams showing the each of the connections.

### 7 Intelli Valves and 1 Variety Valve

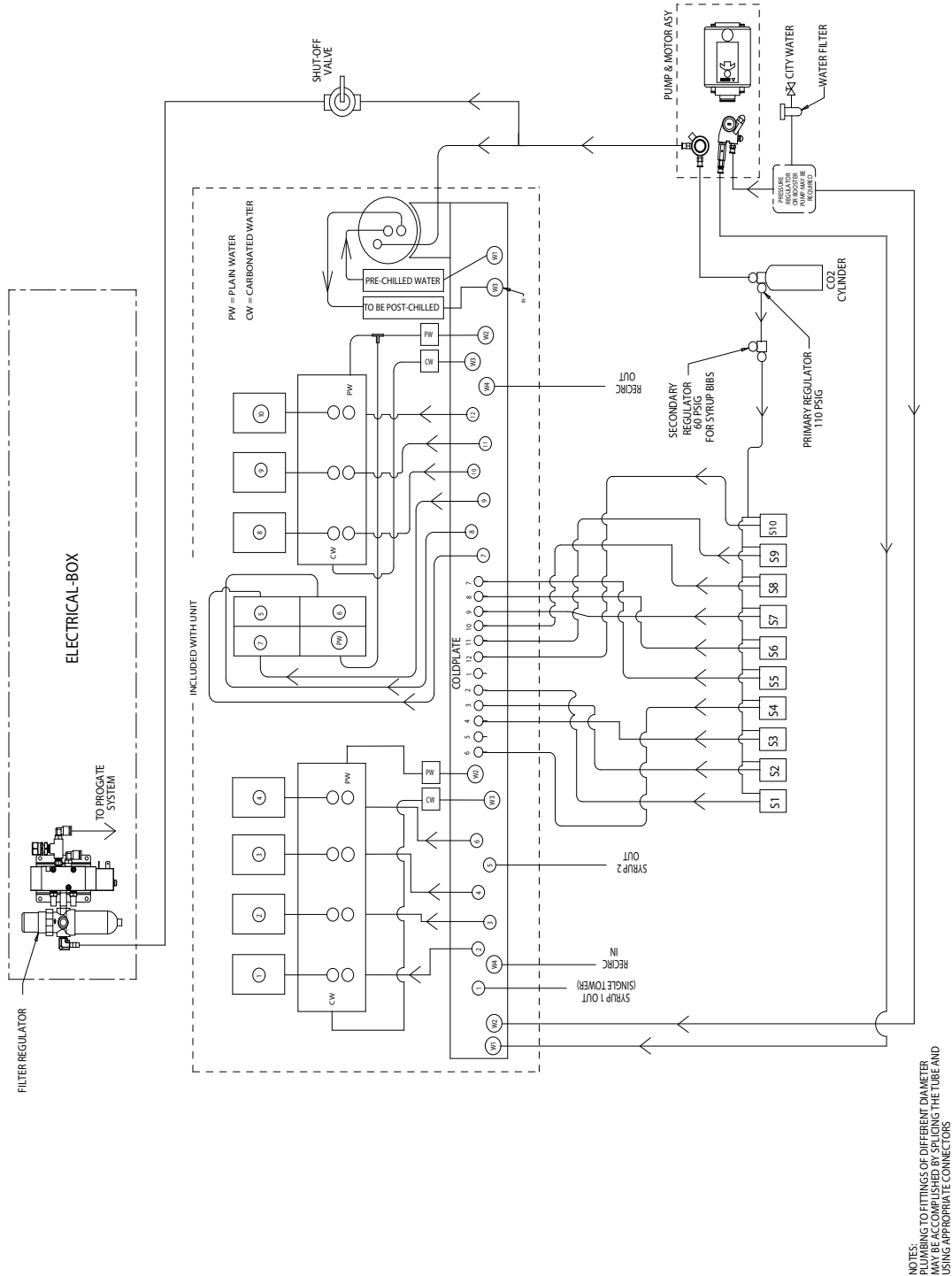

Figure 7.



### 8 Intelli Valves or 8 UFB-1 Valves

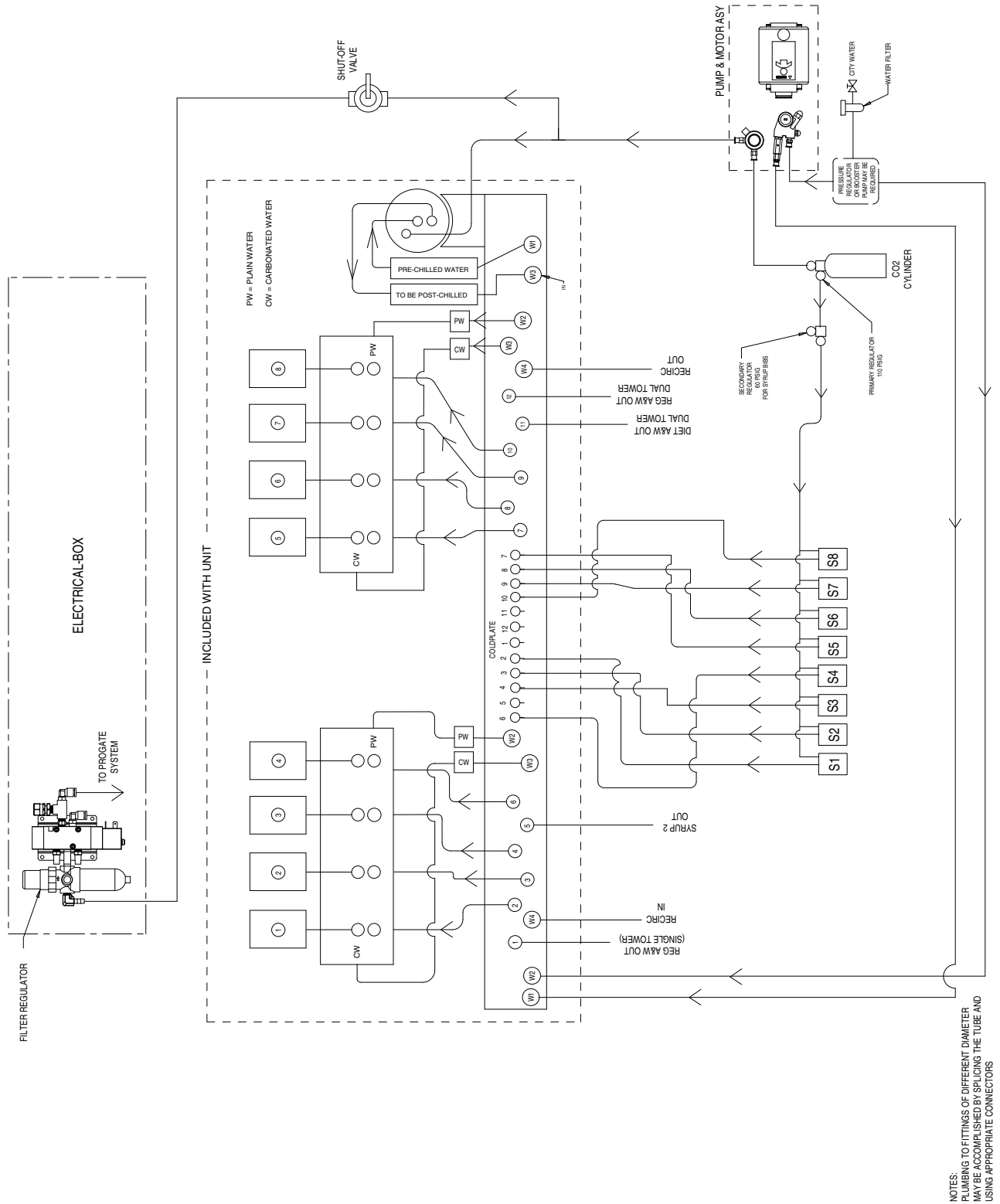

Figure 8.

## E – BOARD OFF CYCLE AGITATION ADJUSTMENTS

When Ice is not being dispensed from the machine such as during off hours it is essential to move or agitate the ice to keep it from clumping and to replenish the ice in the cold plate. The amount of time the agitator runs and the time between the agitation cycles can be adjusted depending on ice type or application. The settings for this function are located on the E-Board found in the E-BOX. To access the board to be adjusted refer to sections 5.1 and 5.3. Using a screwdriver follow the diagram below and set the agitator for the desired settings.

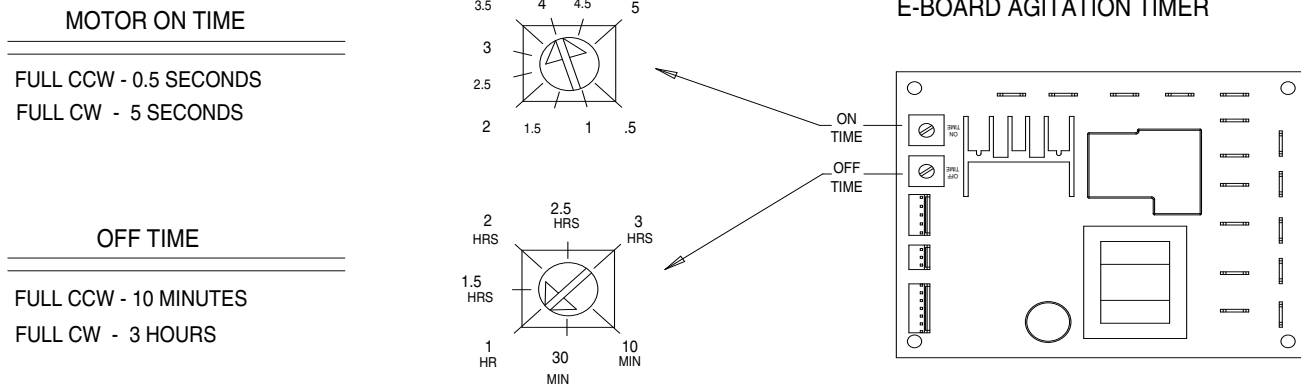

Figure 9.

Manufacturer Recommended Agitation Settings			
Model	Ice Fill/Ice Type	Motor ON Time	Motor OFF time
175, 215, &255, 300, B, BC	Manual/Hard Ice (Cube)	4 Seconds	1 Hour
	Automatic (Top-Mount Ice Maker/Hard Ice (Cube)	0.5 Seconds	20 Minutes
	Manual & Automatic/Cornelius Chunklet, Scotsman & Hoshizaki Compressed Ice	0.5 Seconds	3 Hours
B - Beverage C-Coldplate		*NO FLAKED ICE*	

# ELECTRICAL SCHEMATIC

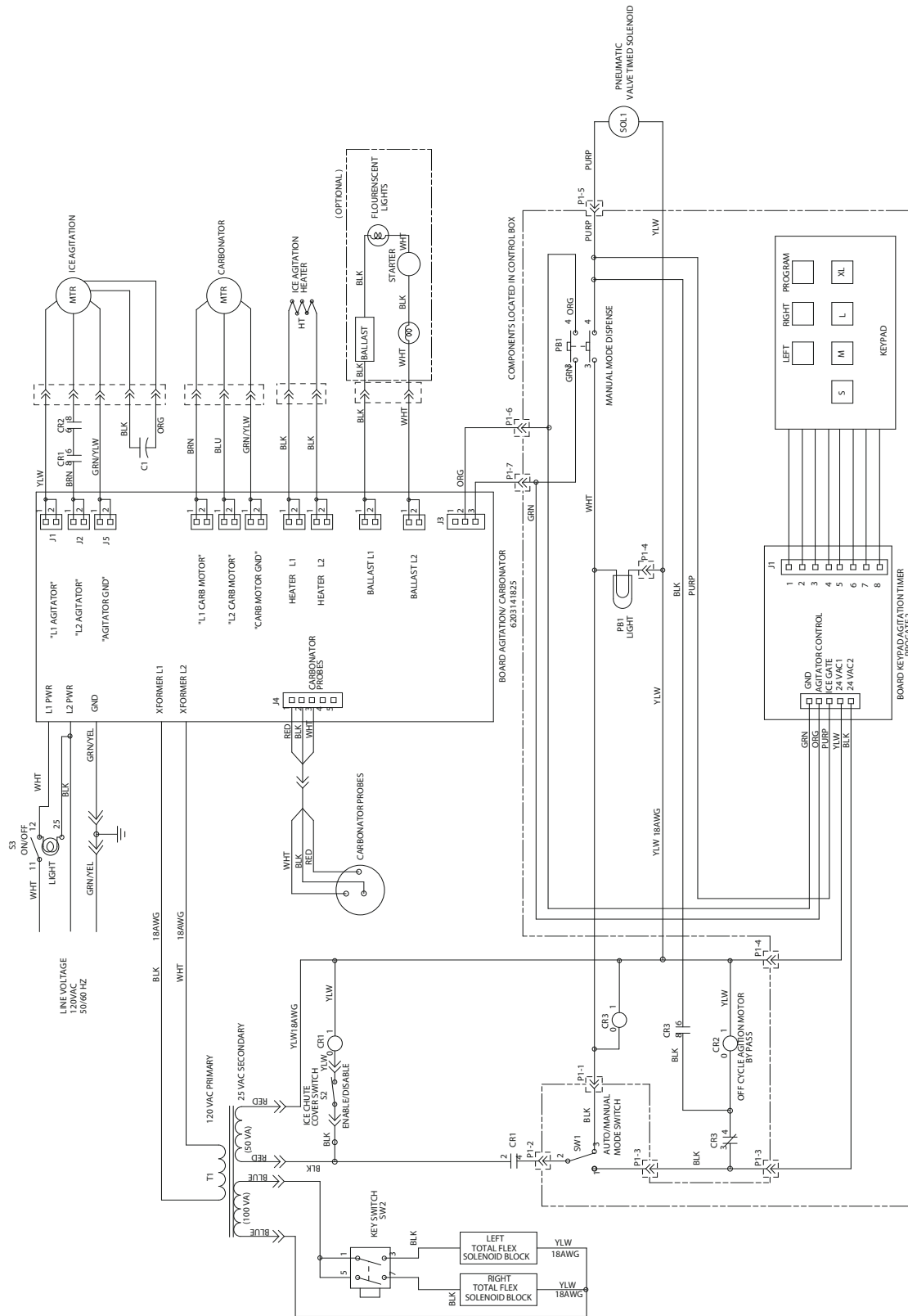

Figure 10.

# MAIN ELECTRICAL BOX ASSEMBLY

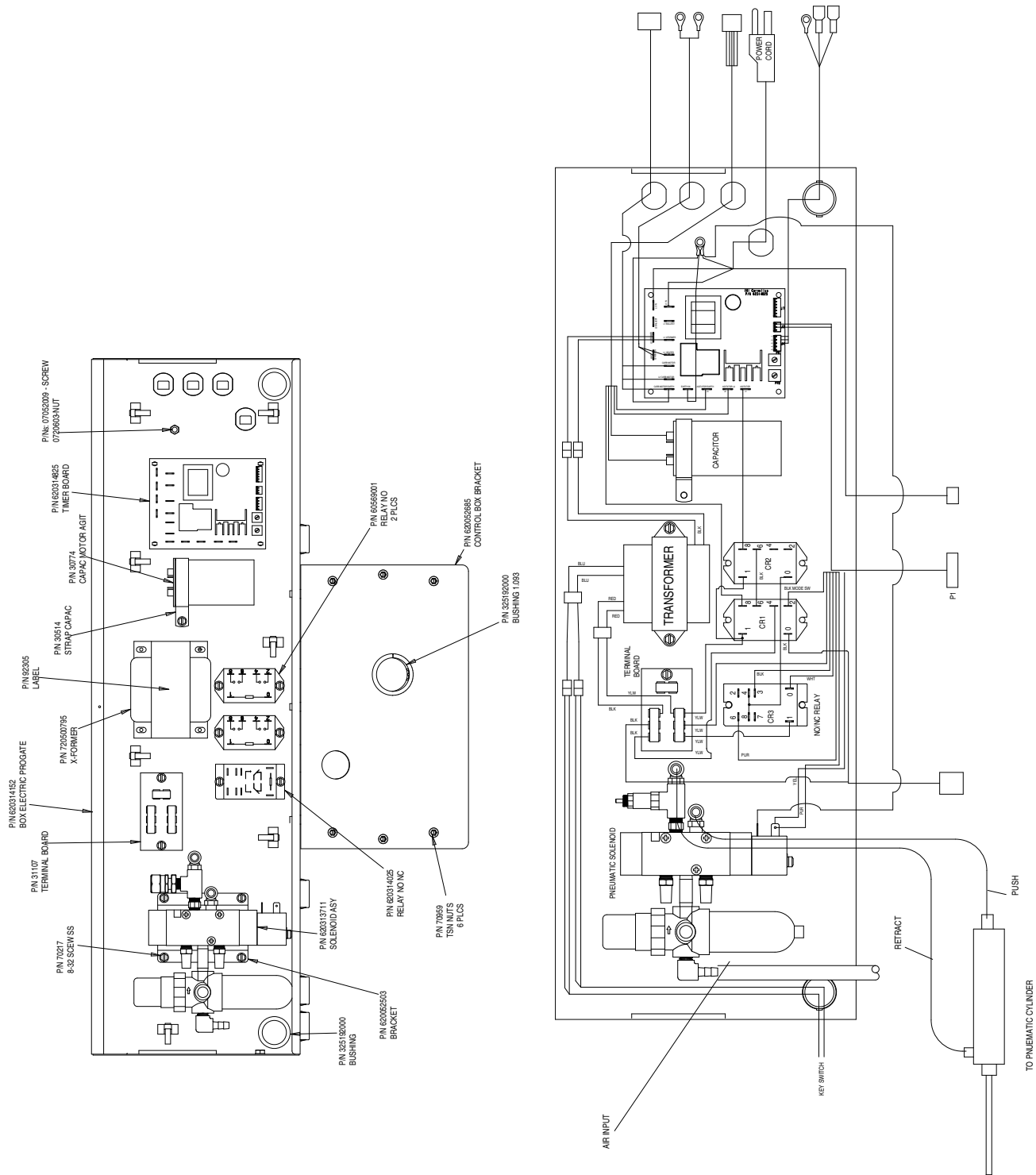

Figure 11.

# INTERCONNECT SCHEMATIC

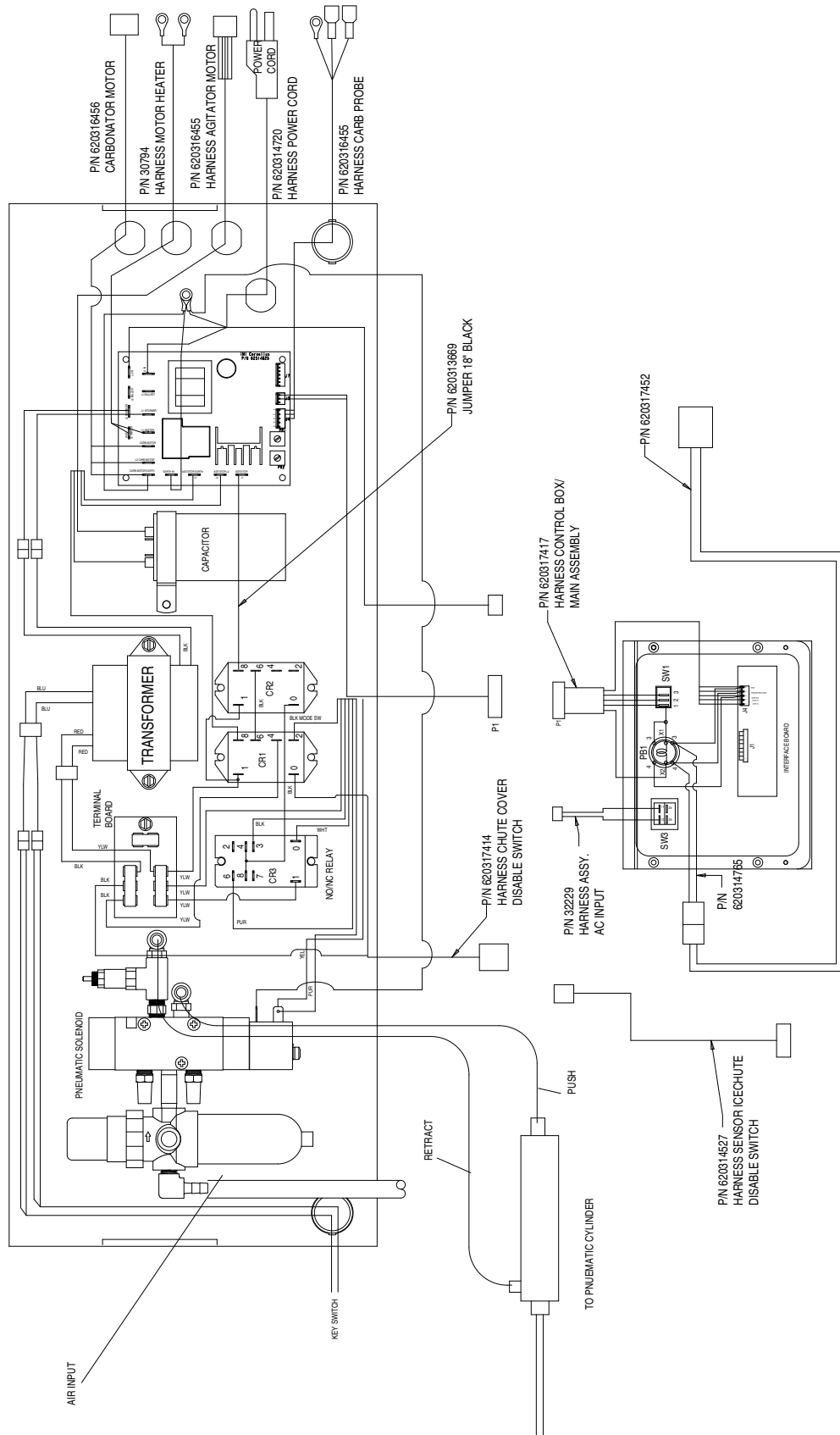

Figure 12.

# CLEANING AND MAINTENANCE INSTRUCTIONS

These instructions are applicable for all Cornelius ice drink dispensers. Some models may have additional cleaning requirements. Those models will have additional procedures listed later in the manual.

## **WARNING:**

Disconnect power to the unit before servicing. Follow all lock out/tag out procedures established by the user. Verify all power is off to the unit before performing any work.

**Failure to comply could result in serious injury, death or damage to the equipment.**

## **CAUTION:**

Do not use metal scrapers, sharp objects or abrasives on the ice storage hopper, top cover, agitator disc or exterior surfaces as it may damage the unit. Do not use solvents or other cleaning agents as they may degrade the material resulting in damage to the unit.

**Soap solution** – Use a mixture of mild detergent and warm (100° F) potable water.

**Sanitizing Solution** – Dissolve 2 packets (4 Oz) of Stera Sheen Green Label into 2 gallons of warm (80 – 100° F) potable water to ensure 200 ppm of chlorine.

## **Daily Cleaning:**

1. Remove cup rest from drip tray and clean with warm soapy water, rinse with clean water and allow to air dry.
2. Wipe down the exterior of the unit with warm soapy water, rinse with clean water and allow to air dry.
3. Remove valve nozzles and diffusers and wash in warm soapy water, rinse in clean water and allow to air dry.
4. Clean the interior of the ice chute using the brush provided with the unit with warm soapy water, rinse with clean water and allow to air dry.
5. Spray the ice chute inside and out with sanitizer and allow to air dry.
6. Pour warm soapy water down the drains to keep them clean and flowing smoothly.
7. Spray the nozzles and diffusers inside and outside with approved sanitizing solution, re-install them on the valves and allow to air dry.
8. Re-install the cup rest into the drip tray.
9. Pour all remaining sanitizer solution down the drain to help keep the drain clear.

## **Daily Maintenance:**

1. Check the temperature, smell and taste of the product.
2. Check the water pressure coming to the unit using the pressure gauges on the back room package.
3. Check carbonation of the drink.
4. Check level of CO2 supply to the system.
5. Check the date on all the BIB's (bags in boxes).

## **Weekly Cleaning: (In addition to daily procedures)**

Remove the ice chute cover and clean it along with the back half with warm soap water using the brush provided with the unit. Rinse with clean water and re-install on the unit. Spray the ice chute assembly with an approved sanitizer and allow it to air dry.

## **Monthly Cleaning: (In addition to daily and weekly procedures)**

1. Flush and sanitize all syrup lines as well as all of the syrup connectors. (See the Sanitize syrup lines section shown later in this manual).
2. Remove ice from hopper, clean and sanitize the hopper. (See the Cleaning the interior surfaces section shown later in this manual).

3. While cleaning the hopper use the brush provided with the unit to clean the cold plate surface. To accomplish this, the brush needs to be extended through the opening in the bottom of the hopper.

### Yearly Maintenance:

1. Have the water pump and check valve inspected and cleaned by a qualified service technician.
2. Has the CO2 gas check valve inspected and cleaned by a qualified service technician.
3. Remove the unit's splash and cold plate cover to clean and sanitize the cold plate surface. (See the Cleaning the Cold Plate section shown later in this manual).

### Lid Dispenser Cleaning

The lid dispensers are manufactured out of materials that can survive chlorine-based cleaners and warm water <100°F. Ensure that the parts are thoroughly dried before refilling with lids.

**Lid dispenser parts should not be soaked in the power soak washing machine as this will result in the parts getting scratched. Instead the dispenser parts should be rinsed in warm soapy water when dry.**

### Ice Chute Cleaning

The Ice chute needs to be cleaned daily to remove buildups.

**NOTE: The ice chute has an built-in safety feature which disables the unit when the ice chute cover is removed. If the ice chute cover is not properly installed the agitator and ice chute gate will not function.**

#### Removing and Reinstalling the Ice Chute:

1. Grab ice chute and slide up until it comes to a stop.
2. Pull forward.
3. Properly clean the ice chute. The ice chute is manufactured out of materials that can survive chlorine-based cleaners and warm water <100°F.

**IMPORTANT: Do not put the ice chute into a dishwasher.**

4. Replace when finished.
5. If agitator or ice chute does not operate remove and re-install chute cover.

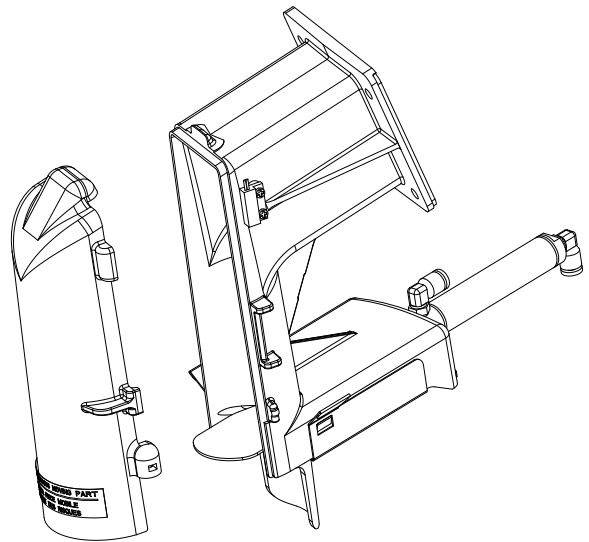

Figure 13.

### Cleaning Interior Surfaces (Monthly Cleaning)

#### CAUTION:

When pouring liquid into the hopper, do not exceed the rate of 1/2 gallon per minute. Pouring more liquid into the hopper could result in an overflow situation which may result in injury or damage to the equipment.

1. Remove agitator assembly.
2. Using a nylon bristle brush or sponge, clean the interior of the hopper, top cover and agitator assembly with soap solution. Thoroughly rinse the hopper, cover and agitator surfaces with clean potable water.
3. Re-assemble agitator assembly. Take special care to ensure that the thumbscrew is tight.
4. Using a mechanical spray bottle filled with sanitizing solution, spray the entire interior and agitator assembly. Allow to air dry.

5. Remove merchandiser and ice chute cover from the unit.
6. With a nylon bristle brush or sponge, clean the inside of the ice chute, gasket, and cover with soap solution and rinse thoroughly to remove all traces of detergent.
7. Re-assemble ice chute assembly.
8. Using a mechanical spray bottle filled with sanitizing solution, spray the inside of the ice chute. Allow to air dry.
9. Reinstall the merchandiser.

### **Cold Plate (Yearly Maintenance)**

1. Remove splash panel.
2. Remove or move the plastic cold plate cover to expose the cold plate.
3. Locate and remove any debris from the drain trough. Check that the drain holes are not clogged.
4. Pour small amount of soap solution through cold plate openings in hopper.
5. Using a cloth, wash down the surfaces of the cold plate and plastic cover with soap solution.
6. Install and properly position the access covers on the cold plate.
7. Install the splash panel in the reverse order it was removed.
8. Rinse cold plate surface by pouring potable water through hopper openings.

### **Dispensing Valves: (Daily Cleaning)**

Refer to addendum supplied with the unit that is applicable to the manufacturer of the valves installed on the unit.

### **Product Tubing (Monthly Cleaning)**

**IMPORTANT: Only trained and qualified persons should perform these cleaning and sanitizing procedures.**

#### **Sanitize Pre-Mix And Post-Mix Tank System**

1. Remove all the quick disconnects from all the tanks. Fill a suitable pail or bucket with soap solution.
2. Submerge all disconnects (gas and liquid) in the soap solution and then clean them using a nylon bristle brush. **(Do not use a wire brush)**. Rinse with clean water.
3. Prepare sanitizing solution and using a mechanical spray bottle, spray the disconnects and allow to air dry.
4. Using a clean, empty tank, prepare five (5) gallons of the sanitizing solution. Rinse the tank disconnects with approximately 9 oz. of the sanitizing solution. Close the tank.
5. Prepare cleaning tank by filling clean five (5) gallon tank with a mixture of mild detergent and potable water (120°F).
6. Connect a gas disconnect to the tank and then apply one of the product tubes to the cleaning tank. Operate the appropriate valve until liquid dispensed is free of any syrup.
7. Disconnect cleaning tank and hook up the sanitizing tank to syrup line and CO<sub>2</sub> systems.
8. Energize beverage faucet until a chlorine sanitizing solution is dispensed through the faucet. Flush at least two (2) cups of liquid to ensure that the sanitizing solution has filled the entire length of the syrup tubing.
9. Allow sanitizer to remain in lines for fifteen (15) minutes.
10. Repeat the step above, applying a different product tube each time until all tubes are filled with the sanitizing solution.
11. Remove the nozzle and syrup diffuser and clean them with a mild soap solution.
12. Rinse with clean water and reassemble the nozzle and syrup diffuser on the valve.
13. Rinse the parts with clean water, reassemble the valve and reconnect it to the dispenser.
14. Discard the tank of sanitizing solution and reconnect the product syrup tanks. Operate the valves until all sanitizer has been flushed from the system and the only product syrup is flowing.



### Sanitize syrup lines, B-I-B Systems

1. Remove all the quick disconnects from all the B-I-B containers.
2. Fill a suitable pail or bucket with soap solution.
3. Submerge all disconnects (gas and liquid) in the soap solution and then clean them using a nylon bristle brush. **(Do not use a wire brush)**. Rinse with clean water.
4. Using a plastic pail, prepare approximately five (5) gallons of sanitizing solution.
5. Rinse the B-I-B disconnects in the sanitizing solution.
6. Sanitizing fittings must be attached to each B-I-B disconnect. If these fittings are not available, the fittings from empty B-I-B bags can be cut from the bags and used. These fittings open the disconnect so the sanitizing solution can be drawn through it.
7. Place all the B-I-B disconnects into the pail of sanitizing solution. Operate all the valves until the sanitizing solution is flowing from the valve. Allow sanitizer to remain in lines for fifteen (15) minutes.
8. Remove the nozzle and the syrup diffuser from each valve and clean them with a soap solution. Rinse with clean water and re-assemble the nozzle and syrup diffuser to the valve.
9. Remove the sanitizing fittings from the B-I-B disconnects and connect the disconnects to the appropriate B-I-B container. Operate the valves until all sanitizer has been flushed from the system and the syrup is flowing freely.

### Replenishing CO<sub>2</sub> Supply (As Required)

**NOTE: When indicator on the 1800-psi gauge is in the shaded (“change CO<sub>2</sub> cylinder”) portion of the dial, CO<sub>2</sub> cylinder is almost empty and should be changed.**

1. Fully close (clockwise) the CO<sub>2</sub> cylinder valve.
2. Slowly loosen the CO<sub>2</sub> regulator assembly coupling nut allowing CO<sub>2</sub> pressure to escape, then remove the regulator assembly from the empty CO<sub>2</sub> cylinder.
3. Unfasten safety chain and remove the empty CO<sub>2</sub> cylinder.



#### **WARNING:**

To avoid personnel injury and/or property damage, always secure the CO<sub>2</sub> cylinder with a safety chain to prevent it from falling over. Should the valve become accidentally damaged or broken off, a CO<sub>2</sub> regulator can cause serious personnel injury or death.

4. Position the full CO<sub>2</sub> cylinder and secure with a safety chain.
5. Make sure gasket is in place inside the CO<sub>2</sub> regulator assembly coupling nut, then install the regulator assembly on the CO<sub>2</sub> cylinder.
6. Open (counter-clockwise) the CO<sub>2</sub> cylinder valve slightly to allow the lines to slowly fill with gas, then open the valve fully to back-seat the valve (back-seating the valve prevents gas leakage around the valve shaft).
7. Check CO<sub>2</sub> connections for leaks. Tighten any loose connections.

# SERVICE

## MERCHANDISER REMOVAL

1. Remove all lid holders and straw dispenser.



Figure 14.



Figure 15.

2. Remove screws holding merchandiser to control box.



Figure 16.

3. Grab panel by sides, lift up to disengage locking tabs and rotate forward past.



Figure 17.

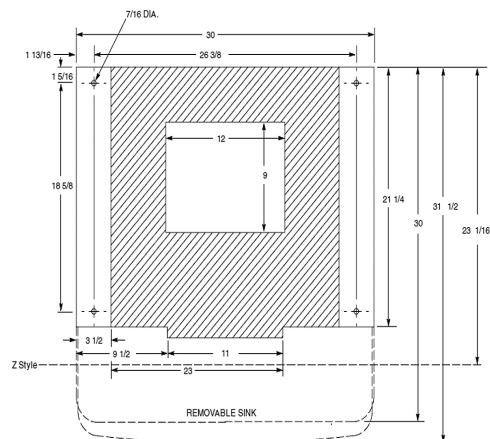

Figure 18.

## CONTROL BOX REMOVAL

1. With cover removed locate and remove 4 screws from Control box flange.



Figure 19.

2. Pull box forward exposing control board, wiring and switches.

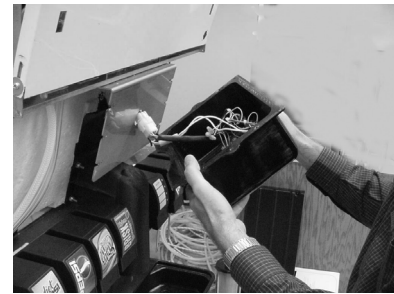

Figure 20.

## MAIN ELECTRICAL BOX ACCESS

1. Remove screw-locking cover to electrical box.



Figure 21.

2. Lift cover up and then rotate forward.



Figure 22.

## ICE CHUTE REMOVAL

1. Remove 4 nuts attaching ice chute to hopper.



Figure 23.

2. Disconnect ice chute switch harness located behind the control box.



Figure 24.

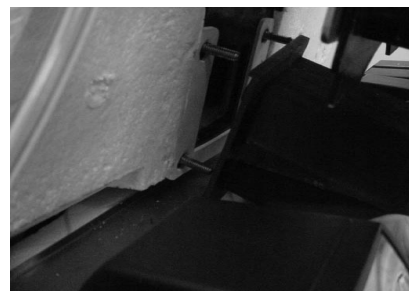

Figure 25.

3. Pull assembly away from hopper. Do not loose or damage gasket. If damaged or missing replace.
4. Pull ice chute assembly out of splash panel and disconnect the CO2 lines.

**NOTE: Mark the CO2 lines to avoid improper assembly.**



Figure 26.

5. View of underside of ice chute assembly showing gate and pneumatic cylinder.



Figure 27.

## MOTOR REMOVAL

**NOTE:** Apply anti-seizing lubricant to the threads of mounting bolts when service is required.

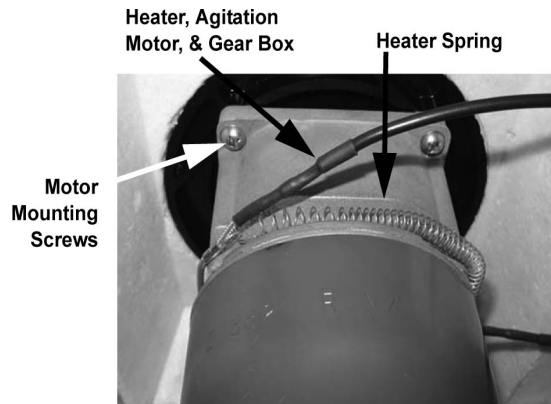

Figure 28.

## DIAGNOSTICS GUIDE FOR THE MAIN CONTROL BOARD

**NOTE:** Refer to Figure 23.

State	Observed State of Red LED	Sensor Input	Control Response	Service Remedy
0	Flash rate 3 seconds	Both probes read "wet"	Standby mode. Pump = OFF	No service required
1	Flash rate 1/2 second	Pump is OFF and HIGH probe reads "dry" and LOW probe reads "wet"	Waiting for level to drop below LOW probe. Pump = OFF	No service required
2	Flash rate 1/2 second	Both HIGH and LOW probes read "dry"	Normal mode. Pump = ON	No service required
3	Flash rate 1/2 second	Entered when HIGH probe does not detect liquid, and LOW probe does detect liquid, and pump is ON	Normal mode. Pump = ON	No service required
4	Flash rate 1 second	Entered when HIGH probe reads "wet" and LOW probe reads "dry"	This is an error condition.	<ul style="list-style-type: none"> <li>- Check electrical connections at the carbonator tank, and at connector J4 on the main control board</li> <li>- Black wire should be connected to the LOW probe and also to Pin 4 of Connector J4</li> <li>- Reverse the connections if incorrect</li> <li>- Replace harness if necessary</li> </ul>
5	ON continuously, but "flickers" every 3 seconds	Poor signal connection to the carbonator tank. May result in short cycling of the carbonator pump.	Able to continue to function but carbonator pump short-cycles. Pump will come on each time a drink is drawn. <b>THIS SITUATION SHOULD BE CORRECTED.</b>	Check the harness connections of the red signal wire at both ends: 1) at the carbonator ring terminal and 2) at Pin 5 of the J4 connector at the main control board
6	ON continuously	Entered when pump has run continuously for 5 minutes	<b>THIS IS AN ERROR CONDITION.</b>	Unplug the unit and plug it back in. This will reset the unit's main control board and restart the carbonator pump.

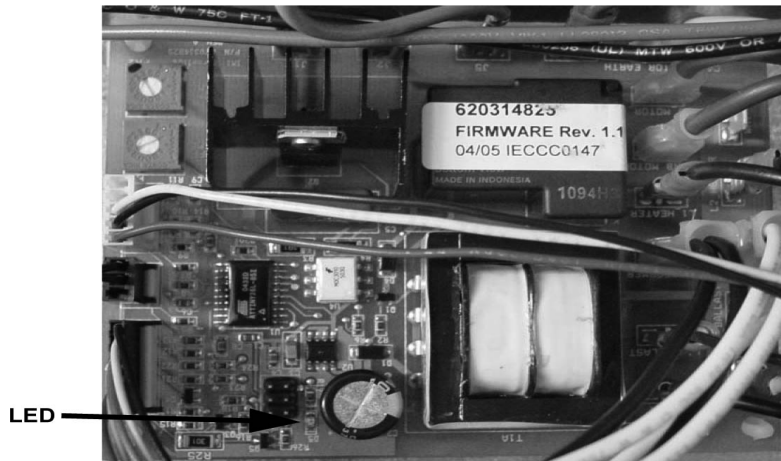
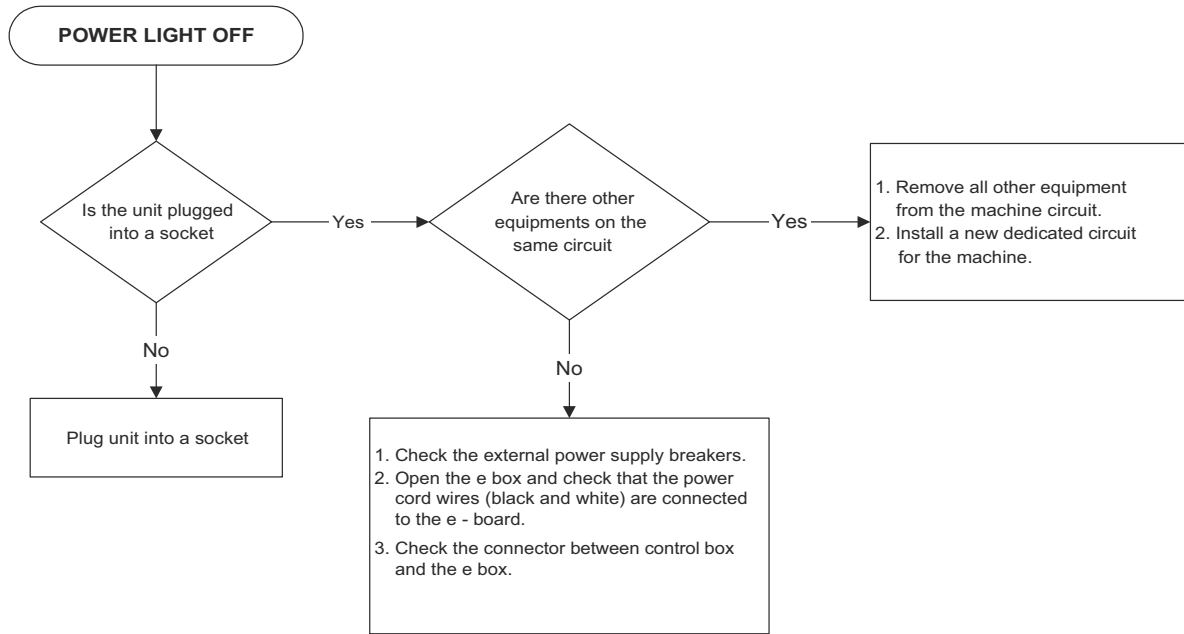

Figure 29.

# TROUBLESHOOTING

## POWER LIGHT OFF



## NO ICE DISPENSE IN MANUAL MODE

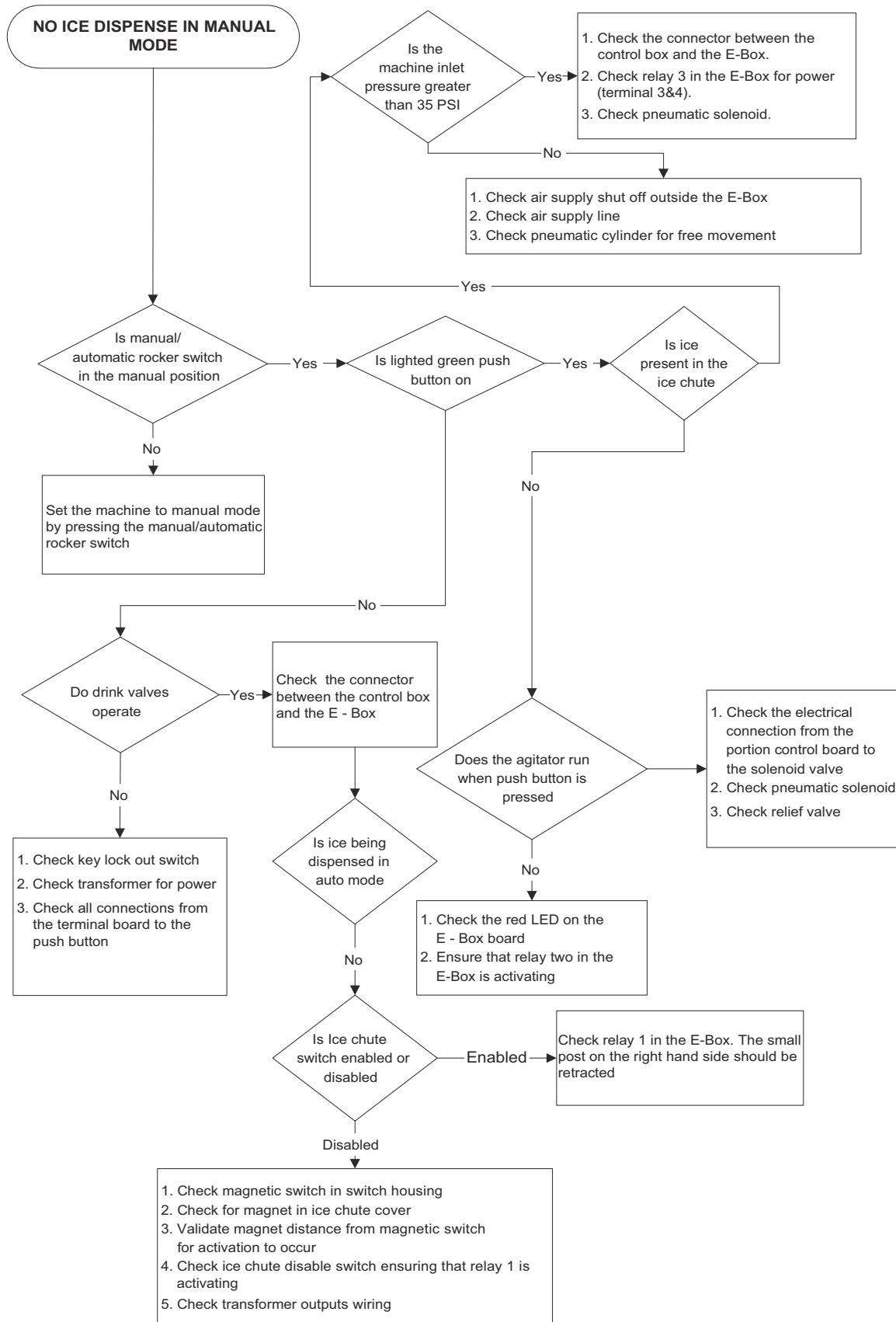



# NO ICE DISPENSE IN AUTOMATIC MODE

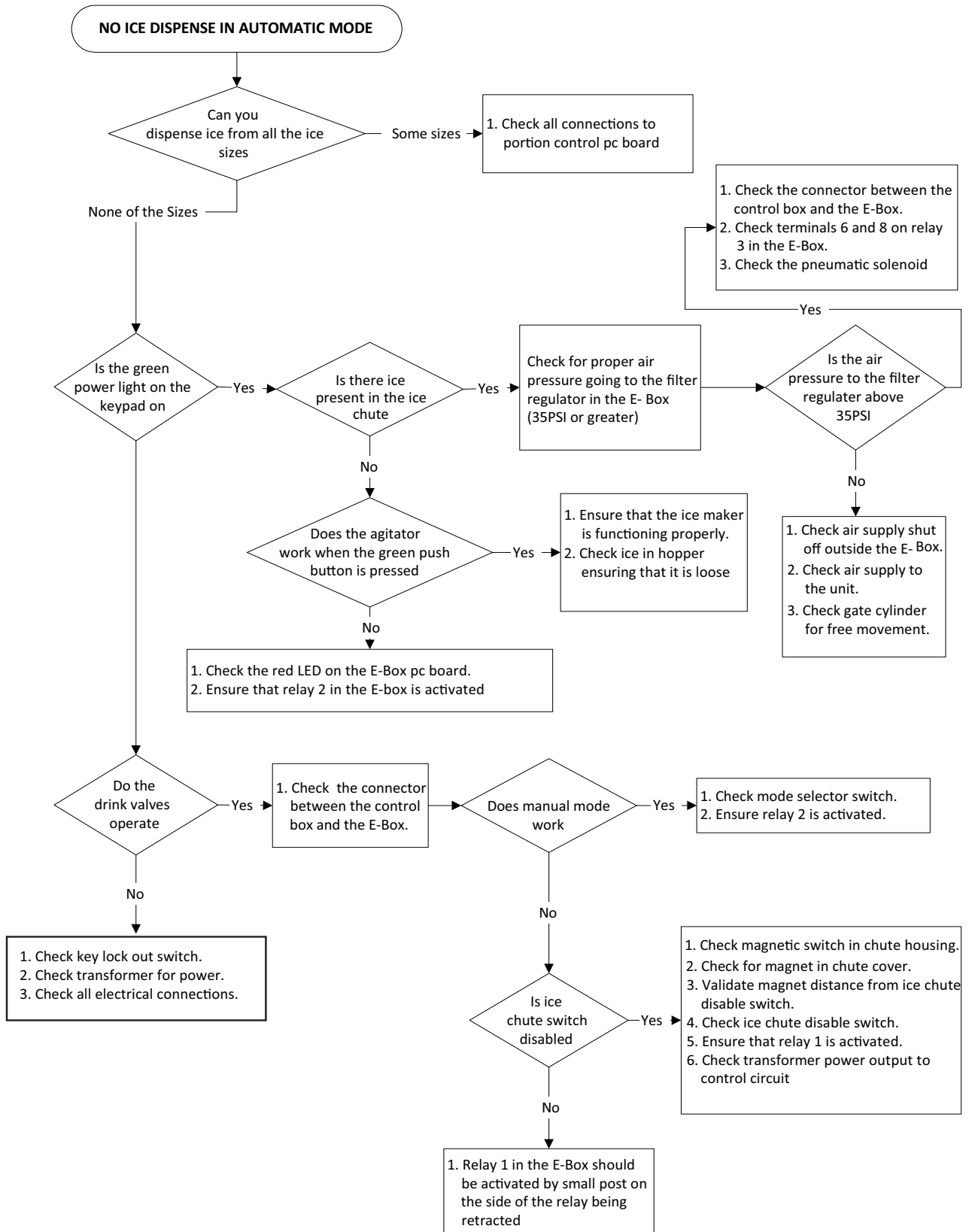

## BEVERAGE NOT DISPENSING

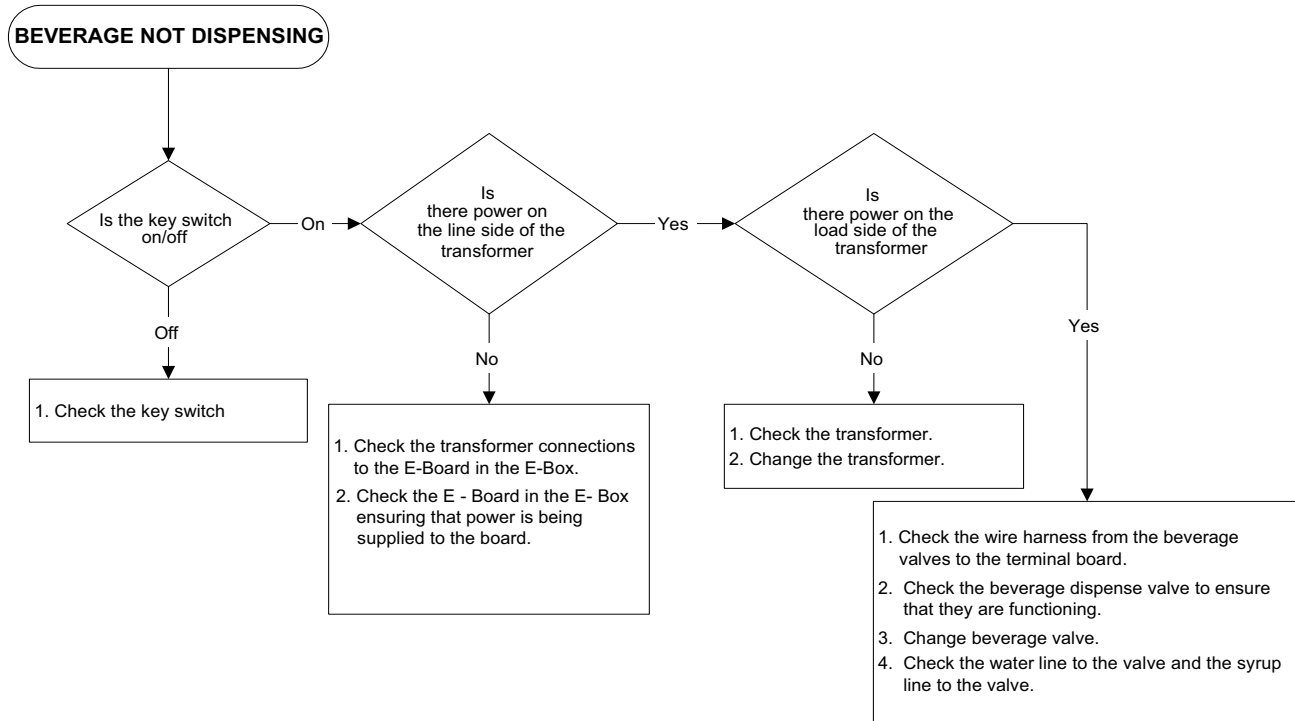

# FLAT DRINKS

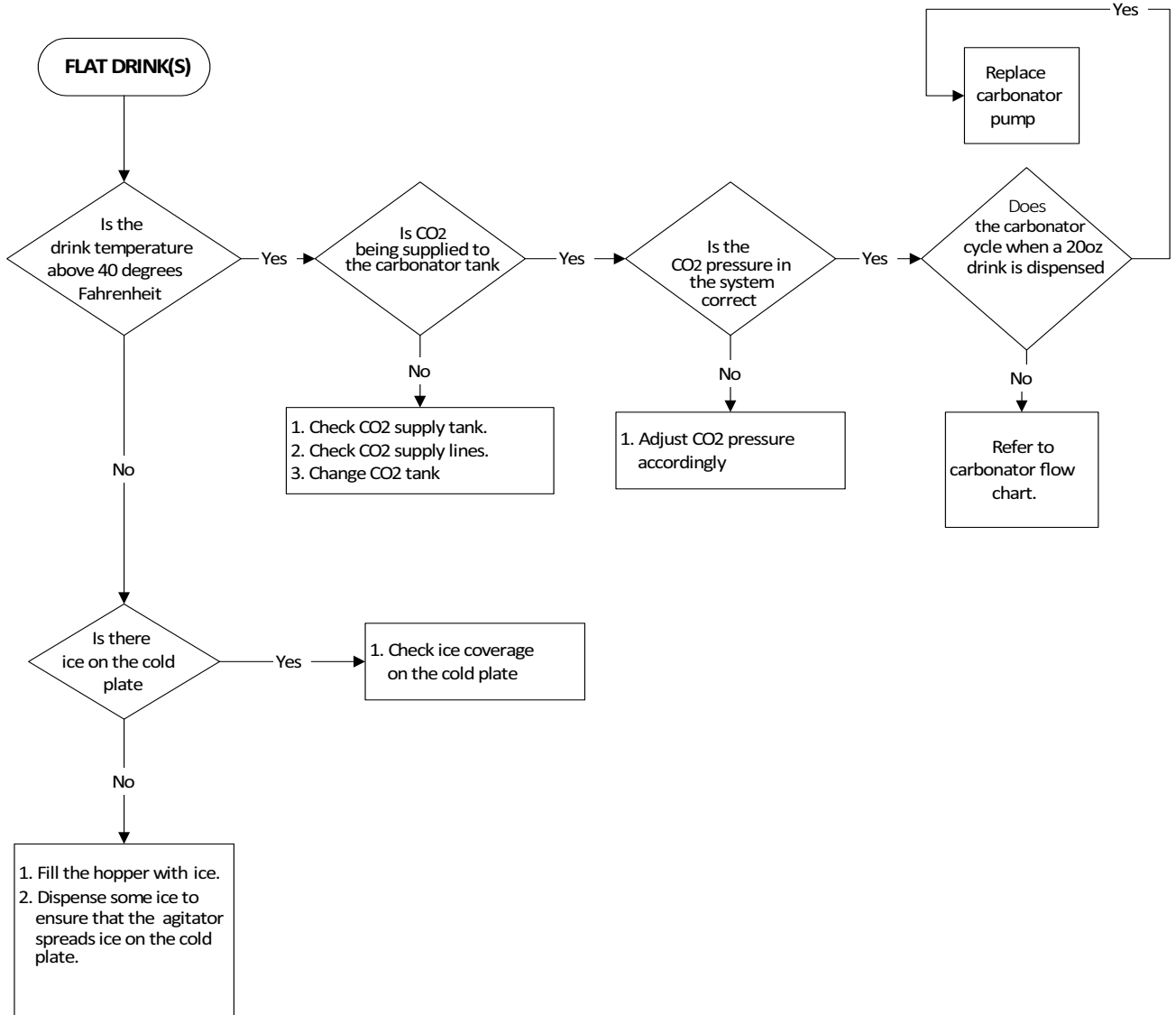

## No CARBONATED WATER

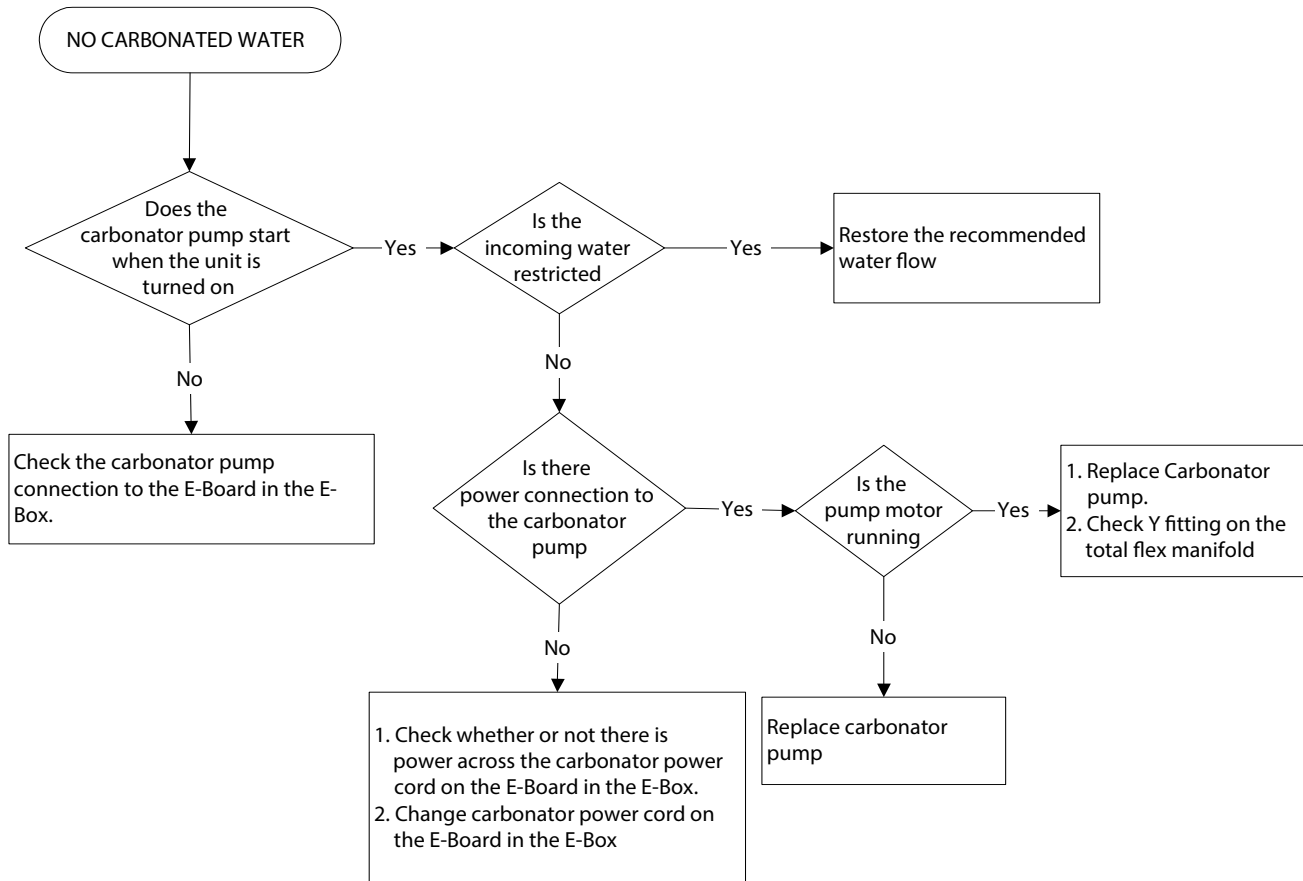



**Cornelius Inc.**  
**[www.cornelius.com](http://www.cornelius.com)**