



IMI CORNELIUS INC ■ One Cornelius Place ■ Anoka, MN 55303-6234

Telephone (800) 238-3600

Facsimile (763) 422-3246

LOW PROFILE LARGE RESERVE CARBONATOR

Operator's Manual

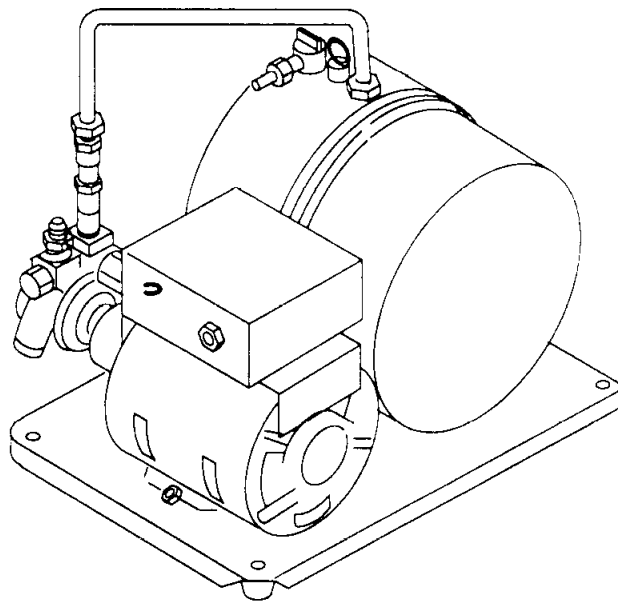

Part No. 319798002
April 4, 1985
Revised: July 9, 2002
Control Code C

THIS DOCUMENT CONTAINS IMPORTANT INFORMATION

This Manual must be read and understood before installing or operating this equipment

© IMI CORNELIUS INC; 1985-2002

TABLE OF CONTENTS

	Page
SAFETY INFORMATION	1
RECOGNIZE SAFETY INFORMATION	1
UNDERSTAND SIGNAL WORDS	1
FOLLOW SAFETY INSTRUCTIONS	1
CO2 (CARBON DIOXIDE) WARNING	1
SHIPPING, STORING, OR RELOCATING UNIT	1
GENERAL INFORMATION	3
TO THE USER OF THIS MANUAL	3
CLAIMS INSTRUCTIONS	3
WARRANTY REFERENCE INFORMATION	3
DESIGN DATA	3
THEORY OF OPERATION	4
OPERATORS INSTRUCTIONS	5
PERIODIC INSPECTION	5
CHECKING CO2 SUPPLY	5
CHECKING FOR CO2 AND WATER LEAKS	5
CHECKING CARBONATED WATER TANK RELIEF VALVE	5
WATER PUMP MOTOR LUBRICATION	5
ADJUSTING CARBONATOR CO2 REGULATOR	5
WATER PUMP YEARLY MAINTENANCE (OR AFTER WATER SYSTEM DISRUPTION)	5
UNIT PART NO. 416424000, 41642400U, 496424000, 49642400U, AND 496424040	5
UNIT PART NO. 1624, AND 411624102	6
PERIODIC CLEANING	6
REPLENISHING CO2 SUPPLY	6
CLEANING CO2 GAS CHECK VALVE	6
TROUBLESHOOTING	7
CARBONATOR WILL NOT OPERATE.	7
WATER PUMP MOTOR WILL NOT SHUT OFF.	7
ERRATIC CYCLING OF CARBONATOR.	7
WATER PUMP MOTOR OPERATES BUT WATER PUMP DOES NOT PUMP WATER.	7
CARBONATOR CARBONATED WATER CAPACITY TOO LOW	7
WARRANTY	8

LIST OF FIGURES

FIGURE 1. LOW PROFILE LARGE RESERVE CARBONATOR	4
--	---

LIST OF TABLES

TABLE 1. DESIGN DATA	3
----------------------------	---

SAFETY INFORMATION

Recognize Safety Information

This is the safety-alert symbol. When you see this symbol on our machine or in this manual, be alert to the potentially of personal injury.

Follow recommended precautions and safe operating practices.



Understand Signal Words

A signal word - **DANGER**, **WARNING**, OR **CAUTION** is used with the safety-alert symbol. **DANGER** identifies the most serious hazards.

Safety signs with signal word **DANGER** or **WARNING** are typically near specific hazards.

General precautions are listed on **CAUTION** safety signs. **CAUTION** also calls attention to safety messages in this manual.



Follow Safety Instructions

Carefully read all safety messages in this manual and on your machine safety signs. Keep safety signs in good condition. Replace missing or damaged safety signs. Learn how to operate the machine and how to use the controls properly. Do not let anyone operate the machine without instructions. Keep your machine in proper working condition. Unauthorized modifications to the machine may impair function and/or safety and affect the machine life.

CO₂ (Carbon Dioxide) Warning

CO₂ Displaces Oxygen. Strict Attention *must* be observed in the prevention of CO₂ (carbon dioxide) gas leaks in the entire CO₂ and soft drink system. If a CO₂ gas leak is suspected, particularly in a small area, *immediately* ventilate the contaminated area before attempting to repair the leak. Personnel exposed to high concentration of CO₂ gas will experience tremors which are followed rapidly by loss of consciousness and suffocation.

Maximum CO₂ Operating Pressure 75-PSI

Shipping, Storing, Or Relocating Unit

CAUTION: Before shipping, storing, or relocating this Unit, the syrup systems must be sanitized and all sanitizing solution *must* be purged from the syrup systems. All water *must* also be purged from the plain and carbonated water systems. A freezing ambient temperature will cause residual water remaining inside the Unit to freeze resulting in damage to internal components of the Unit.

THIS PAGE LEFT BLANK INTENTIONALLY

GENERAL INFORMATION

TO THE USER OF THIS MANUAL



CAUTION: This Unit must not be installed in an unsheltered outdoor location where it will be exposed to the elements.

This is an Operator's manual for the Low Profile Large Reserve Carbonator (hereafter referred to as a Unit) shown in Figure 1. Retain this manual with your equipment manuals for future reference.

This Unit must be serviced by a qualified Service Person. This Unit contains no user serviceable parts.

CLAIMS INSTRUCTIONS

Claims: In the event of shortage, notify the carrier as well as IMI Cornelius immediately. In the event of damage, notify the carrier. **IMI Cornelius is not responsible for damage occurring in transit, but will gladly render assistance necessary to pursue your claim. Merchandise must be inspected for concealed damage within 15 days of receipt.**

WARRANTY REFERENCE INFORMATION

Warranty Registration Date (to be filled out by customer)
Unit Part Number:
Serial Number:
Install Date:
Local Authorized Service Center:

DESIGN DATA

Table 1. Design Data	
Unit Part Numbers:	
115 VAC, 50/60 Hz Unit (Liquid dual check valve)	41642400U
115 VAC, 50/60 Hz Unit (Liquid dual check valve)	416424000
115 VAC, 50/60 Hz Unit (Vented dual check valve)	1624
115 VAC, 50/60 Hz Unit (Vented dual check valve)	411624102
220 VAC, 50 Hz/230 VAC, 60 Hz Unit (Liquid dual check valve)	496424000
230 VAC, 50 Hz Unit (Liquid dual check valve)	496424040
230 VAC, 50 Hz Unit (Liquid dual check valve)	49642400U

Table 1. Design Data (cont'd)	
Overall Dimensions:	
Width	15-1/2 inches
Height	13 inches
Depth	11-1/4 inches
Weight:	
Dry	27 pounds
Shipping	32 pounds
Ambient Operating Temperature	40° F to 100° F
Maximum CO ₂ Operating Pressure	125-PSI
Electrical Requirements:	
115 VAC, 50/60 Hz Unit:	
Current Draw	8.1/6.5 Amps
Operating Voltage	115VAC, 50/60 Hz
230 VAC, 50 Hz Unit	
Current Draw	3.3 Amps
Operating Voltage	230VAC, 60 Hz

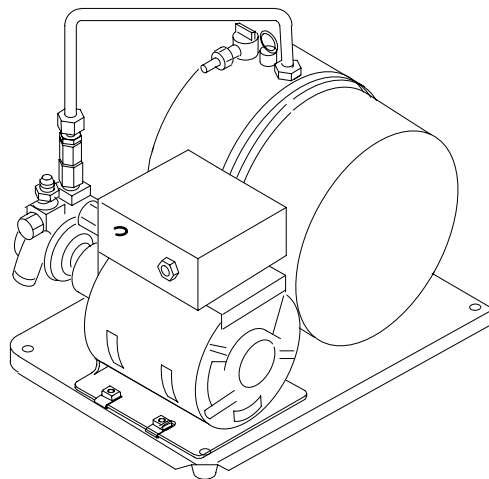

FIGURE 1. LOW PROFILE LARGE RESERVE CARBONATOR

THEORY OF OPERATION

A CO₂ cylinder delivers CO₂ (carbon dioxide) gas through an adjustable CO₂ regulator to the carbonator water tank. At the same time, plain water is pumped into the carbonator water tank by the water pump and is carbonated by CO₂ gas also entering the tank. When carbonator water tank carbonated water level has been satisfied, liquid level sensing device inside the tank signals the liquid level control module which in turn shuts off the water pump motor and the water pump. As carbonated water is drawn and carbonated water level in the tank drops to a certain level, the liquid level sensing device inside the water tank signals the liquid level control module that carbonated water must be replenished which in turn starts the water pump motor and the pump.

OPERATORS INSTRUCTIONS



CAUTION: To prevent a fire hazard, no object should be placed or stored on top of the Unit.

This section covers operators cleaning and maintenance responsibilities for the Unit.

PERIODIC INSPECTION

CHECKING CO₂ SUPPLY

Make sure CO₂ cylinder regulator assembly 1800-psi gage indicator is not in shaded (“change CO₂ cylinder”) portion of dial. If so, CO₂ cylinder is almost empty and must be replaced.

CHECKING FOR CO₂ AND WATER LEAKS

Check Unit for CO₂ and water leaks and if found, call a qualified Service Person to repair as necessary.

CHECKING CARBONATED WATER TANK RELIEF VALVE

The relief valve on top of the carbonated water tank should be periodically checked for operation by briefly pulling up on the relief valve ring.

WATER PUMP MOTOR LUBRICATION

Water pump motor bearings must be lubricated periodically. Call a qualified Service Person to perform the bearings lubrication procedure.

ADJUSTING CARBONATOR CO₂ REGULATOR

The carbonator CO₂ regulator should be periodically checked for proper CO₂ gas pressure setting (nominal-80 psig, *DO NOT EXCEED 125 PSIG*). If adjustment is necessary, call a qualified Service Person to perform the adjustment procedure.

WATER PUMP YEARLY MAINTENANCE (OR AFTER WATER SYSTEM DISRUPTION)

UNIT PART NO. 416424000, 41642400U, 496424000, 49642400U, AND 496424040

The water pump water strainer screen and liquid dual check valve must be inspected and cleaned at least once a year under normal circumstances and after any water system disruption (plumbing work, earthquake, etc.). Call a qualified Service Person to inspect and clean the strainer screen and liquid dual check valve.

UNIT PART NO. 1624, and 411624102

The water pump water strainer screen must be inspected and cleaned at least once a year under normal circumstances and after any water system disruption (plumbing work, earthquake, etc.). Call a qualified Service Person to inspect and clean the water strainer screen.

IMPORTANT: A vented dual-check valve assembly is installed in the carbonator between the water pump outlet and the water inlet to the carbonator tank. The vented dual-check valve assembly vents carbonated water, and possibly CO₂ gas out of a vent port upon failure of the primary check valves. Should such venting occur, call a qualified Service Person to replace the vented dual-check valve assembly.

PERIODIC CLEANING

Periodically wash all external surfaces of the Unit, rinse with clean water, then wipe dry with a clean soft cloth. DO NOT USE ABRASIVE-TYPE CLEANERS.

REPLENISHING CO₂ SUPPLY

NOTE: When indicator on CO₂ cylinder regulator assembly 2000-psi gage is in shaded (“change CO₂ cylinder”) portion of the dial, CO₂ cylinder is almost empty and should be changed.

1. Fully close (clockwise) CO₂ cylinder valve.
2. Slowly loosen CO₂ regulator assembly coupling nut allowing CO₂ pressure to escape, then remove regulator assembly from empty CO₂ cylinder.
3. Unfasten safety chain and remove empty CO₂ cylinder.



WARNING: To avoid personnel injury and/or property damage, always secure the CO₂ cylinder with a safety chain to prevent it from falling over. Should the valve become accidentally damaged or broken off, a CO₂ cylinder can cause serious personnel injury.

4. Position the CO₂ cylinder and secure with a safety chain.
5. Make sure gasket is in place inside the CO₂ regulator coupling nut, then install regulator on the CO₂ cylinder.
6. Open (counterclockwise) CO₂ cylinder valve slightly to allow lines to slowly with gas, then open valve fully to back-seat the valve (back-seating the valve prevents leakage around the valve shaft).
7. Check CO₂ connections for leaks. Tighten any loose connections.

CLEANING CO₂ GAS CHECK VALVE

The CO₂ gas check valve, located on carbonator tank, must be inspected and serviced at least once a year under normal conditions and after any CO₂ system servicing or disruption. Call a qualified Service Person to inspect and clean the CO₂ gas check valve.

TROUBLESHOOTING



WARNING: Disconnect electrical power to the carbonator to prevent personal injury before attempting any internal maintenance. Only qualified personnel should service the internal components or the electrical wiring.

If repairs to the carbonated water or the plain water systems must be made, disconnect electrical power to the Unit, then shut off CO₂ and plain water sources. Dispense from dispensing valve until carbonator tank CO₂ pressure has been relieved.

Trouble	Probable Cause	Remedy
CARBONATOR WILL NOT OPERATE.	A. Power cord unplugged or circuit breaker open in panel box.	A. Plug in power cord or reset circuit breaker.
	B. Inoperative carbonator.	B. Call a qualified Service Person.
WATER PUMP MOTOR WILL NOT SHUT OFF.	A. Carbonator internal problem.	A. Call a qualified Service Person.
ERRATIC CYCLING OF CARBONATOR.	A. Carbonator internal problem.	A. Call a qualified Service Person.
WATER PUMP MOTOR OPERATES BUT WATER PUMP DOES NOT PUMP WATER.	A. Carbonator internal problems or a water supply line problem.	A. Call a qualified Service Person.
CARBONATOR CARBONATED WATER CAPACITY TOO LOW	A. Carbonator internal problems or a water supply line problem.	A. Call a qualified Service Person.
	B. Water filter clogged.	B. Replace water filter.

WARRANTY

IMI Cornelius Inc. warrants that all equipment and parts are free from defects in material and workmanship under normal use and service. For a copy of the warranty applicable to your Cornelius, Remcor or Wilshire product, in your country, please write, fax or telephone the IMI Cornelius office nearest you. Please provide the equipment model number, serial number and the date of purchase.

IMI Cornelius Offices

AUSTRALIA • P.O. 210, • RIVERWOOD, • NSW 2210, AUSTRALIA • (61) 2 533 3122 • FAX (61) 2 534 2166
AUSTRIA • AM LANGEN FELDE 32 • A-1222 • VIENNA, AUSTRIA • (43) 1 233 520 • FAX (43) 1-2335-2930
BELGIUM • BOSKAPELLEI 122 • B-2930 BRAASCHAAT, BELGIUM • (32) 3 664 0552 • FAX (32) 3 665 2307
BRAZIL • RUA ITAOCARA 97 • TOMAS COELHO • RIO DE JANEIRO, BRAZIL • (55) 21 591 7150 • FAX (55) 21 593 1829
ENGLAND • TYTHING ROAD ALCESTER • WARWICKSHIRE, B49 6 EU, ENGLAND • (44) 789 763 101 • FAX (44) 789 763 644
FRANCE • 71 ROUTE DE ST. DENIS • F-95170 DEUIL LA BARRE • PARIS, FRANCE • (33) 1 34 28 6200 • FAX (33) 1 34 28 6201
GERMANY • CARL LEVERKUS STRASSE 15 • D-4018 LANGENFELD, GERMANY • (49) 2173 7930 • FAX (49) 2173 77 438
GREECE • 488 MESSOGION AVENUE • AGIA PARASKEVI • 153 42 • ATHENS, GREECE • (30) 1 600 1073 • FAX (30) 1 601 2491
HONG KONG • 1104 TAIKOTSUI CENTRE • 11-15 KOK CHEUNG ST • TAIKOKTSUE, HONG KONG • (852) 789 9882 • FAX (852) 391 6222
ITALY • VIA PELLIZZARI 11 • I-20059 • VIMARCATI, ITALY • (39) 39 608 0817 • FAX (39) 39 608 0814
NEW ZEALAND • 20 LANSFORD CRES. • P.O. BOX 19-044 AVONDALE • AUCKLAND 7, NEW ZEALAND • (64) 9 8200 357 • FAX (64) 9 8200 361
SINGAPORE • 16 TUAS STREET • SINGAPORE 2263 • (65) 862 5542 • FAX (65) 862 5604
SPAIN • POLIGONO INDUSTRIAL • RIERA DEL FONOLLAR • E-08830 SANT BOI DE LLOBREGAT • BARCELONA, SPAIN • (34) 3 640 2839 • FAX (34) 3 654 3379
USA • ONE CORNELIUS PLACE • ANOKA, MINNESOTA • (612) 421-6120 • FAX (612) 422-3255

LD004
4/21/98

THIS PAGE LEFT BLANK INTENTIONALLY

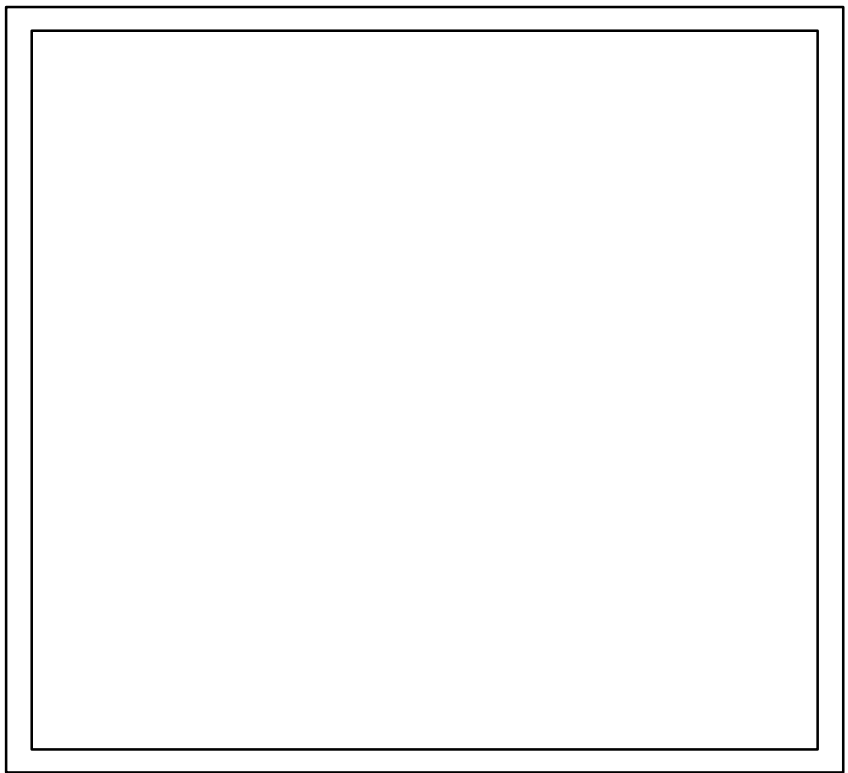

IMI CORNELIUS INC.

CORPORATE HEADQUARTERS:

One Cornelius Place
Anoka, Minnesota 55303-6234
(763) 421-6120
(800) 238-3600

